

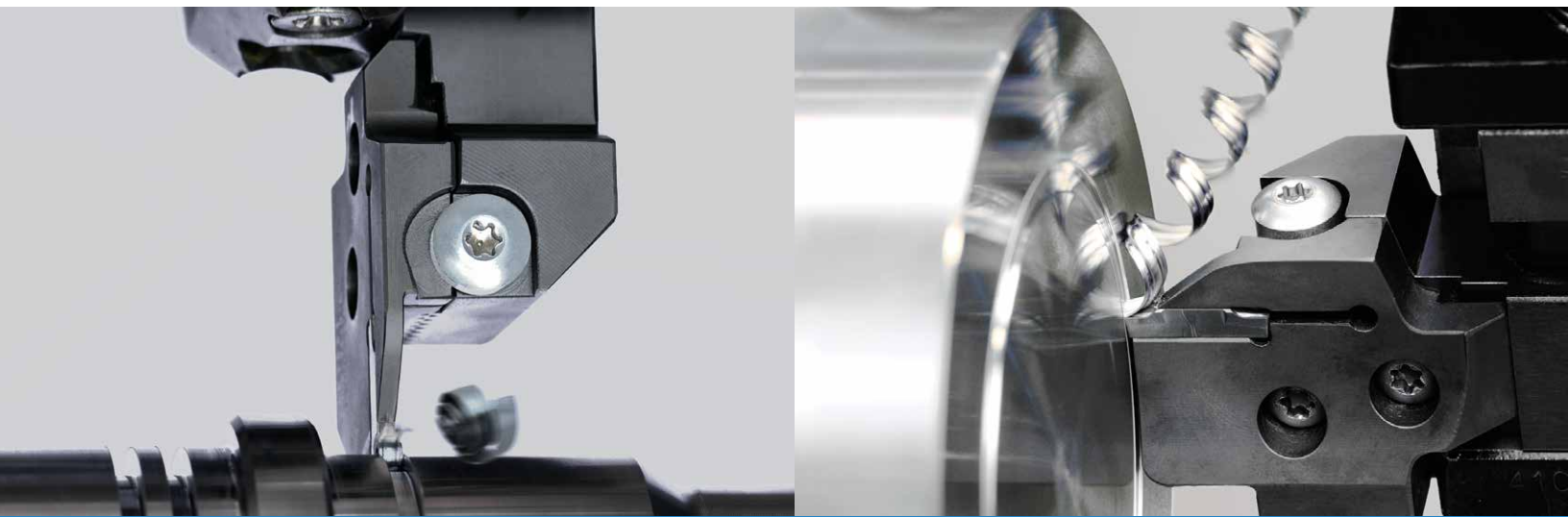

# KGD/KGDF

Grooving / Cut-Off



Improved Grooving Performance with Expansive Tooling System Lineup

Good Chip Control

MEGACOAT Coating Technology for Long Tool Life and High Efficiency Machining

Comprehensive Toolholder Lineup



Holders with 1" Max Groove Depth



# KGD External Grooving / Cut-Off

Good Chip Control

MEGACOAT Coating Technology for Long Tool Life and High Efficiency Machining

## 1 Wide Range of Chipbreakers

### Application Maps

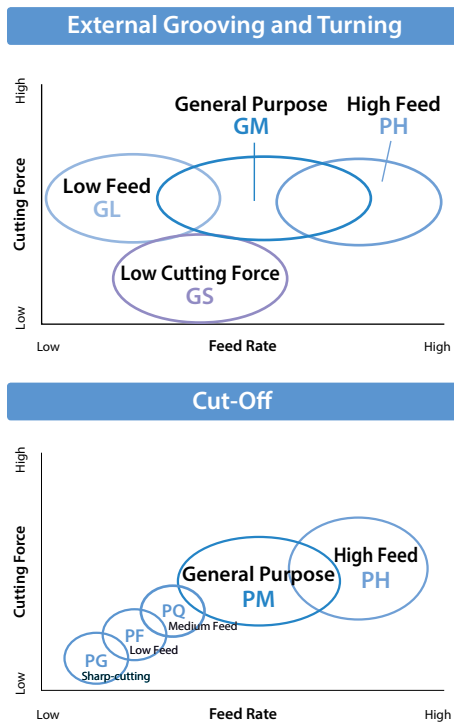

### Chipbreaker Selection (External)

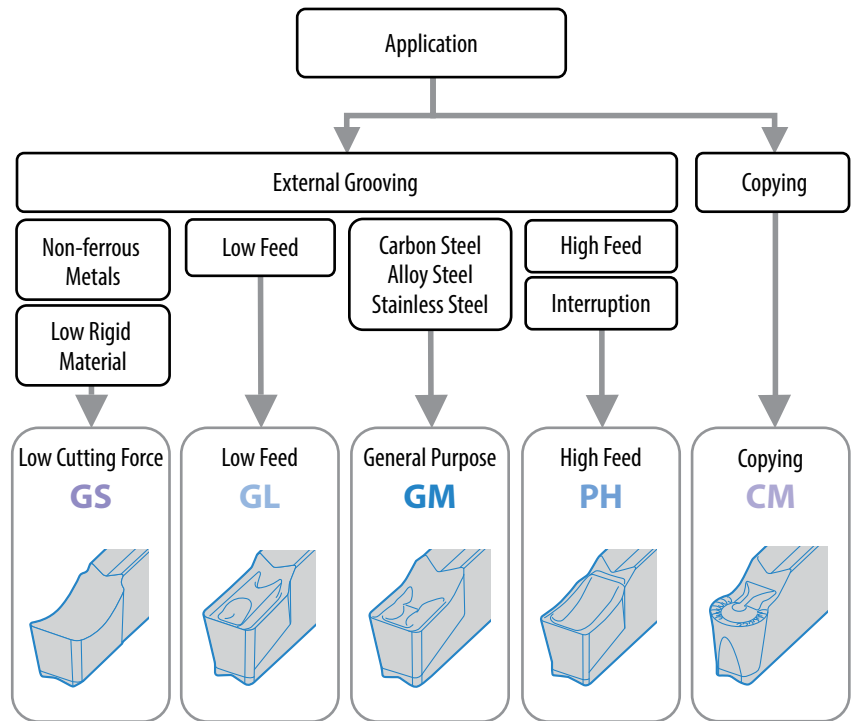

### Chip Control Comparison (In-house Evaluation)

Cutting Conditions :  $V_c = 490$  sfm,  $f = 0.006$  ipr Workpiece : Chromium Molybdenum Steel

### Better Chip Control than Competitors

Reduces Damage of Cutting Edge Caused by Crushing Chips

GM Chipbreaker



Competitor A



Competitor B



## 2 MEGACOAT / MEGACOAT NANO Coating Technology for Long Tool Life

### Coating Properties

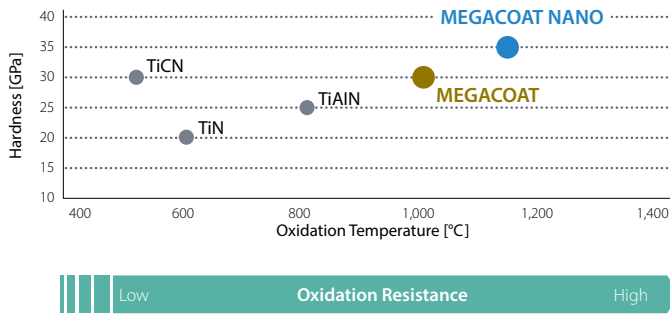

**PR1225 (MEGACOAT)**  
For Steel Grooving and Cut-off

**PR1215 (MEGACOAT)**  
Superior wear resistance  
For machining of cast iron

**PR1535 (MEGACOAT NANO)**  
For machining of stainless steel

## 3 Expansive Toolholder Lineup

### Integral Type and SwitchBlade Type Toolholders for Various Applications

#### Integral Type



#### SwitchBlade Type



Integral type toolholders with a wide lineup of inserts for various groove widths and depths

SwitchBlade type toolholders with replaceable blades for various types of grooving and cut-off operations

### Integral vs. SwitchBlade Selection Guide

Integral	SwitchBlade
<ul style="list-style-type: none"> <li>• Various toolholder lineup Available for various grooving depths (shallow / medium / deep) Optimum overhang length</li> <li>• Available for low-rigidity machines and workpieces</li> <li>• For small machines with limited work space (Automatic lathe, small lathe, etc.)</li> </ul>	<ul style="list-style-type: none"> <li>• Good for high-mix low-volume production Good for various groove widths by replacing blades</li> <li>• Good for difficult-to-cut material Tough cutting conditions Toolholder cost reduction with replaceable blades</li> <li>• Face grooving is possible by changing blade * Be sure to check the hand compatibility of the blade and toolholder</li> </ul>

### Face Grooving KGDF Toolholder and GDFM Inserts [P21](#)



Unique "W Grip" (insert anti-slip structure) provides stable machining quality

1. Prevents abnormal machining surface and/or insert breakage resulting from insert slipping
2. Improves repetitive installation accuracy of insert

High rigidity, reliability and clamping strength

\*GDFM / GDFMS inserts are not compatible with KGD external grooving and cut-off holders

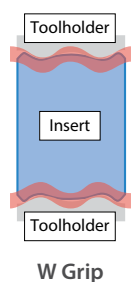

# GDM / GDMS / GDG (External Grooving & Turning)

## Applicable Inserts

Usage Classification	P	Carbon Steel / Alloy Steel	●	○	●	⊖	⊖	
		M	Stainless Steel			●	⊖	⊖
	K	Cast Iron					●	
	N	Non-ferrous Metals						●
	S	Titanium Alloy			●			⊖
	H	Hard Materials (≤40HRC)				○		
		Hard Materials (≥40HRC)						

- : Light Interruption / 1st Choice
- ⊖ : Light Interruption / 2nd Choice
- : Continuous / 1st Choice
- : Continuous / 2nd Choice

Insert	Part Number	Dimensions (in)							Cermet		MEGA COAT NANO	MEGACOAT		Carbide
		W			rε	M	L	H	TN620	TN90	PR1535	PR1225	PR1215	GW15
		inch	mm	Tolerance										
Grooving and Turning General Purpose	GDM 2420N-020GM	0.094	2.4	±0.0012	0.008	0.077	0.787	0.169	○	○	●	●	●	
	3020N-020GM	0.118	3.0		0.008	0.091			○	●	●	●		
	3020N-040GM	0.118	3.0		0.016	0.091			○	○	●	●	●	
	4020N-020GM	0.157	4.0		0.008	0.130			●	○	○	●	●	
	4020N-040GM	0.157	4.0		0.016	0.130			●	○	●	●	●	
	4020N-080GM	0.157	4.0	0.032	0.130	○	○	○	●	●				
	5020N-040GM	0.197	5.0	±0.0016	0.016	0.165	○	○	○	●	●	●		
	5020N-080GM	0.197	5.0		0.032	0.165	○	○	○	●	●	●		
	6020N-040GM	0.236	6.0		0.016	0.205	○	○	○	●	●	●		
	6020N-080GM	0.236	6.0		0.032	0.205	○	○	○	●	●	●		
8030N-080GM	0.315	8.0	±0.0020		0.032	0.236	1.181	0.217			●	●	●	
Grooving and Turning General Purpose 1-Edge	GDMS 2220N-020GM	0.087	2.2	±0.0012	0.008	0.069	0.787	0.169	○	○	○	○	○	
	3020N-040GM	0.118	3.0		0.016	0.091			○	○	○	○	○	
	4020N-040GM	0.157	4.0		0.016	0.130			○	○	○	○	○	
	5020N-080GM	0.197	5.0	±0.0016	0.032	0.165	○	○	○	○	○			
	6020N-080GM	0.236	6.0		0.032	0.205	○	○	○	○	○			
Grooving and Turning Low Feed	GDM 2420N-020GL	0.094	2.4	±0.0012	0.008	0.077	0.787	0.169	○	○	●	○	○	
	3020N-020GL	0.118	3.0		0.008	0.091			○	○	○	○	○	
	3020N-040GL	0.118	3.0		0.016	0.091			○	○	○	○	○	
	4020N-020GL	0.157	4.0	±0.0016	0.008	0.130	○	○	○	○	○			
	4020N-040GL	0.157	4.0		0.016	0.130	○	○	○	○	○			
	5020N-040GL	0.197	5.0		0.016	0.165	○	○	○	○	○			
6020N-040GL	0.236	6.0	0.016	0.205	○	○	○	○	○					
Grooving Low Cutting Force	GDG 2520N-020GS	0.098	2.5	±0.0008	0.008	0.079	0.787	0.169	○	○	●	○	○	●
	3020N-020GS	0.118	3.0		0.008	0.091			○	○	○	○	○	●
	3520N-020GS	0.138	3.5		0.008	0.110			○	○	○	○	○	●
	4020N-040GS	0.157	4.0		0.016	0.130			○	○	○	○	○	●
	5020N-040GS	0.197	5.0		0.016	0.165			○	○	○	○	○	●
	6020N-040GS	0.236	6.0	0.016	0.205	○	○	○	○	○	○			
8030N-040GS	0.315	8.0	0.016	0.236	1.181	0.217	○	○	○	○	○			
Full-R / Copying	GDM 3020N-150R-CM	0.118	3.0	±0.0012	0.059	0.091	0.787	0.169	○	○	○	○	○	
	4020N-200R-CM	0.157	4.0		0.079	0.130			○	○	○	○	○	
	5020N-250R-CM	0.197	5.0	±0.0016	0.098	0.165	*0.827		○	○	○	○		
	6020N-300R-CM	0.236	6.0		0.118	0.205	○		○	○	○	○		
Grooving and Cut-Off (High-Feed)	GDM 2020N-020PH	0.079	2.0	±0.0012	0.008	0.059	0.787	0.169			○	○	○	
	3020N-030PH	0.118	3.0		0.012	0.091					○	○	○	
	4020N-030PH	0.157	4.0		0.012	0.130					○	○	○	
Grooving and Cut-Off (High-Feed) 1-Edge	GDMS 2020N-020PH	0.079	2.0	±0.0012	0.008	0.059	0.787				○	○	○	
	3020N-030PH	0.118	3.0		0.012	0.091					○	○	○	
	4020N-030PH	0.157	4.0		0.012	0.130					○	○	○	

\* GDM50/60-CM differs from other part numbers in length (L) to avoid interference of a toolholder with workpiece.

● : U.S. Stock ○ : World Express (Shipping: 7-10 Business Days)

Inserts sold in 10 piece boxes

### \* KGD / KGM Combinations

#### Insert Pocket Angle of KGD / KGM Toolholders

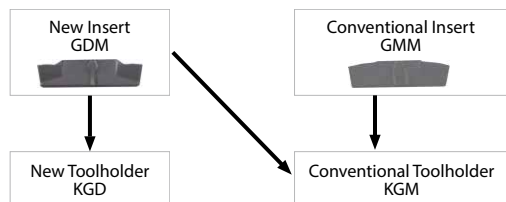
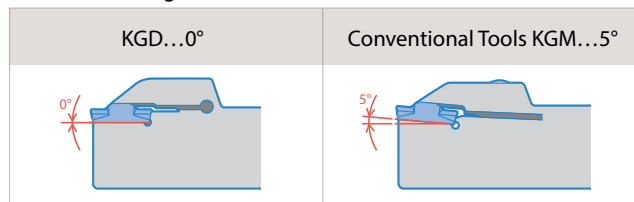



Installing conventional inserts into new KGD toolholder is not recommended.



# GDGS (CBN & PCD) / GDM / GDG (Cut-Off)









## Applicable Inserts

Insert		Part Number	Dimensions (in)		Angle	MEGACOAT CBN	CBN	PCD						
			W	ε					M	L	H	S	θ	
Grooving 	1-Edge 	GDGS 2020N-020NB	0.079	2.0	±0.0012	0.008	0.071	0.787	0.169	0.114	-	○	○	○
		3020N-020NB	0.118	3.0		0.008	0.091					○	○	○
		3020N-040NB	0.118	3.0		0.016	0.091					●	○	○
		4020N-020NB	0.157	4.0		0.008	0.130					○	○	○
		4020N-040NB	0.157	4.0		0.016	0.130					●	○	○
		5020N-020NB	0.197	5.0		0.008	0.165					○	○	○
		5020N-040NB	0.197	5.0		0.016	0.165					○	○	○
		6020N-020NB	0.236	6.0		0.008	0.205					○	○	○
		6020N-040NB	0.236	6.0		0.016	0.205					○	○	○

● : U.S. Stock ○ : World Express (Shipping: 7-10 Business Days)

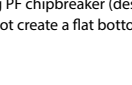
PCD & CBN Inserts sold in 1 piece boxes

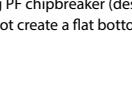
## Applicable Inserts

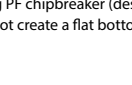
Insert		Part Number	Dimensions (in)		Angle	MEGA COAT NANO	MEGACOAT	DLC Coated Carbide	Carbide						
			W	ε						M	L	H	θ		
Cut-Off (Low Feed) 	15° Lead Angle 	GDM 1316N-003PF	0.051	1.3	±0.0016	0.0012	0.039	0.630	0.146	-	○	○	○		
		1316N-015PF	0.051	1.3		0.0059	0.039				○	○	○		
		1516N-003PF	0.059	1.5		0.0012	0.047				●	●	○		
		1516N-015PF	0.059	1.5		0.0059	0.047				●	●	○		
		2020N-003PF	0.079	2.0		0.0012	0.067				●	●	○		
		2020N-015PF	0.079	2.0		0.0059	0.067				●	●	○		
		2520N-003PF	0.098	2.5		0.0012	0.083				●	○	○		
		2520N-015PF	0.098	2.5		0.0059	0.083				●	●	○		
		3020N-003PF	0.118	3.0		0.0012	0.091				○	●	○		
		3020N-015PF	0.118	3.0		0.0059	0.091				○	●	○		
		GDM 1316% -003PF-15D	0.051	1.3		0.0012	0.039				○	○	○		
		1516% -003PF-15D	0.059	1.5		0.0012	0.047				○	Ⓡ	○		
1516% -015PF-15D	0.059	1.5	0.0059	0.047	Ⓡ	Ⓡ	Ⓡ								
2020% -003PF-15D	0.079	2.0	0.0012	0.067	○	Ⓡ	○								
2020% -015PF-15D	0.079	2.0	0.0059	0.067	Ⓡ	Ⓡ	Ⓡ								
2520% -003PF-15D	0.098	2.5	0.0012	0.083	○	○	○								
2520% -015PF-15D	0.098	2.5	0.0059	0.083	Ⓡ	Ⓡ	Ⓡ								
3020% -003PF-15D	0.118	3.0	0.0012	0.091	○	●	○								
3020% -015PF-15D	0.118	3.0	0.0059	0.091	Ⓡ	Ⓡ	Ⓡ								
Cut-Off (Medium Feed) 	15° Lead Angle 	GDM 2020N-010PQ	0.079	2.0	±0.0012	0.0039	0.067	0.787	0.169	-	○	●			
		2520N-010PQ	0.098	2.5			0.083				○	●			
		3020N-010PQ	0.118	3.0			0.091				○	●			
Cut-Off (Low Cutting Force) 	15° Lead Angle 	GDM 2020R-010PQ-15D	0.079	2.0	±0.0012	0.0039	0.067	0.787	0.169	15°	○	○			
		2520R-010PQ-15D	0.098	2.5			0.083				○	○			
		3020R-010PQ-15D	0.118	3.0			0.091				○	○			
Cut-Off (Low Cutting Force) 	15° Lead Angle 	GDG 2020N-005PG	0.079	2.0	±0.0008	0.0020	0.067	0.787	0.169	-	○	○	○	●	
		2520N-005PG	0.098	2.5			0.083				○	○	○	○	
		3020N-005PG	0.118	3.0			0.091				○	○	○	○	
Cut-Off (Low Cutting Force) 	15° Lead Angle 	GDG 2020R-005PG-15D	0.079	2.0	±0.0008	0.0020	0.067	0.787	0.169	15°	○	○	○	○	
		2520R-005PG-15D	0.098	2.5			0.083				○	○	○	●	○
		3020R-005PG-15D	0.118	3.0			0.091				○	○	○	○	●

Using PF chipbreaker (designed for cut-off) for grooving will not create a flat bottom (See Fig.)



● : U.S. Stock Ⓡ : U.S. Stock (R-hand Only) ○ : World Express (Shipping: 7-10 Business Days) Ⓡ : World Express (R-hand Only)

Inserts sold in 10 piece boxes

Applicable Inserts

Usage Classification	P	Carbon Steel / Alloy Steel	☐	●	☐
● : Light Interruption / 1st Choice	M	Stainless Steel	●	☐	☐
☐ : Light Interruption / 2nd Choice	N	Non-ferrous Metals			

Insert	Part Number	Dimensions (in)				Angle θ	MEGA COAT NANO					
		W			rε		M	L	H	PR1535	PR1225	PR1215
		inch	mm	Tolerance								
	GDM 2020N-020PM	0.079	2.0	±0.0012	0.008	0.059	0.787	0.169	-	●	●	●
	2520N-020PM	0.098	2.5		0.008	0.077				●	●	●
	3020N-025PM	0.118	3.0		0.010	0.091				●	●	●
	4020N-030PM	0.157	4.0		0.012	0.130				●	●	●
	GDM 2020%-020PM-6D	0.079	2.0	±0.0012	0.008	0.059	0.787	0.169	6°	Ⓡ	Ⓡ	Ⓡ
	2520%-020PM-6D	0.098	2.5		0.008	0.077				Ⓡ	Ⓡ	Ⓡ
	3020%-025PM-6D	0.118	3.0		0.010	0.091				Ⓡ	Ⓡ	Ⓡ
	GDMS 2020N-020PM	0.079	2.0	±0.0012	0.008	0.059	0.787	0.169	-	○	●	●
	3020N-025PM	0.118	3.0		0.010	0.091				●	○	○
	4020N-030PM	0.157	4.0		0.012	0.130				○	○	○
	GDMS 2020%-020PM-6D	0.079	2.0	±0.0012	0.008	0.059	0.787	0.169	6°	Ⓡ	Ⓡ	Ⓡ
	3020%-025PM-6D	0.118	3.0		0.010	0.091				Ⓡ	Ⓡ	Ⓡ
	4020%-030PM-6D	0.157	4.0		0.012	0.130				Ⓡ	Ⓡ	Ⓡ

Using PF chipbreaker (designed for cut-off) for grooving will not create a flat bottom (See Fig.)

● : U.S. Stock ● : U.S. Stock (R-hand Only)  
○ : World Express (Shipping: 7-10 Business Days) Ⓡ : World Express (R-hand Only)

Inserts sold in 10 piece boxes

Insert Identification System

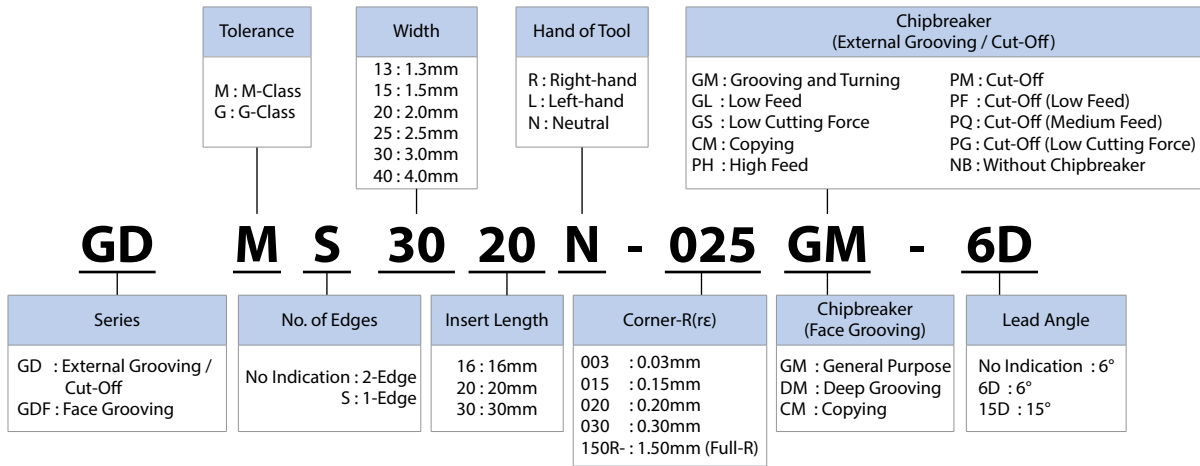

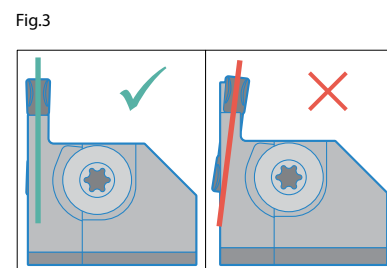
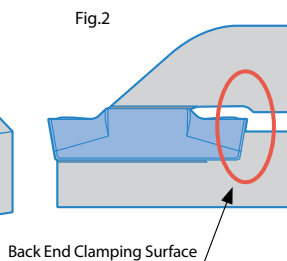
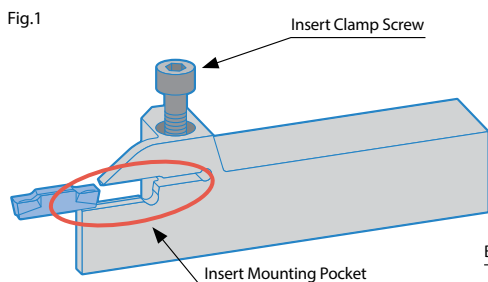

Setting the Insert

1. Completely remove dust and chips from the insert mounting pocket. (see Fig.1)
2. Put the insert into the toolholder and push until it contacts the holder's surface for fixing the insert's back end. (see Fig.1, Fig.2)
3. Keeping the insert pushed against the toolholder's locating surface, tighten the insert clamp screw at an appropriate torque. (Recommended tightening torque for clamp screw is 6.5Nm for HH5X○○, 8.0Nm for HH6X25, and 2.5Nm for SE-50125TR)
4. Make sure there is no gap between the insert and the toolholder's locating surface and that the insert is set straight. (see Fig.2, Fig.3)

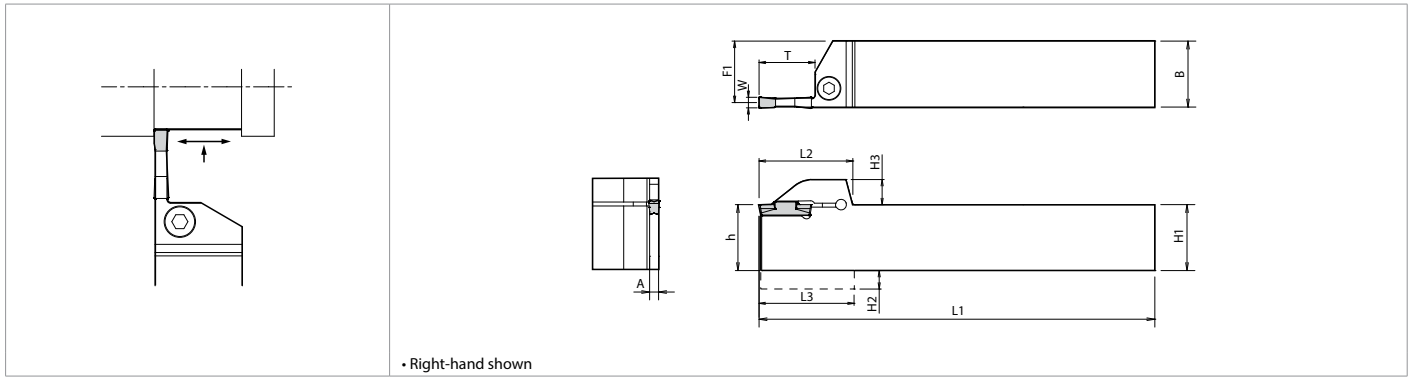



Toolholder Dimensions (Inch Size)

Width (in)	Max. Grooving Depth (in)	Part Number	Stock		Dimensions (in)										Insert Width W (in)		Spare Parts				
																	Clamp Bolt	Wrench			
																					
R	L	H1=h	H2	H3	B	L1	L2	L3	F1	A	T*	MIN	MAX								
0.079 (2mm)	0.669 (17mm)	KGD <sup>R/L</sup> 12-2T17	●	●	0.75	-	0.374	0.75	4.92	1.28	-	0.71	0.067	0.669 (17mm)	0.079 (2mm)	0.118 (3mm)	HH5X16	LW-4			
		16-2T17	●	●	1.00	-	0.374	1.00	5.90	1.28	-	0.96	0.067	0.669 (17mm)			HH5X25				
0.118 (3mm)	0.394 (10mm)	KGD <sup>R/L</sup> 12-3T10	●	●	0.75	-	0.374	0.75	4.92	1.20	-	0.70	0.094	0.394 (10mm)	0.118 (3mm)	0.157 (4mm)	HH5X16	LW-4			
		16-3T10	●	●	1.00	-	0.374	1.00	5.90	1.20	-	0.95	0.094	0.394 (10mm)			HH5X25				
	0.787 (20mm)	KGD <sup>R/L</sup> 12-3T20	●	●	0.75	-	0.374	0.75	4.92	1.35	-	0.70	0.094	0.787 (20mm)			HH5X16	LW-4			
		16-3T20	●	●	1.00	-	0.374	1.00	5.90	1.39	-	0.95	0.094	0.787 (20mm)			HH5X25				
	NEW 1.000 (25.4mm)	0.787 (20mm)	KGD <sup>R/L</sup> 12-3T254	●	●	0.75	-	0.374	0.75	4.92	1.52	-	0.70	0.094			1.000 (25.4mm)	0.118 (3mm)	0.157 (4mm)	HH5X16	LW-4
			16-3T254	●	●	1.00	-	0.374	1.00	5.90	1.52	-	0.95	0.094			1.000 (25.4mm)			HH5X25	
0.157 (4mm)	0.394 (10mm)	KGD <sup>R/L</sup> 12-4T10	●	●	0.75	-	0.374	0.75	4.92	1.20	-	0.68	0.133	0.394 (10mm)	0.157 (4mm)	0.197 (5mm)	HH5X16	LW-4			
		16-4T10	●	●	1.00	-	0.374	1.00	5.90	1.20	-	0.93	0.133	0.394 (10mm)			HH5X25				
	0.787 (20mm)	KGD <sup>R/L</sup> 12-4T20	●	●	0.75	-	0.374	0.75	4.92	1.35	-	0.68	0.133	0.787 (20mm)			HH5X16	LW-4			
		16-4T20	●	●	1.00	-	0.374	1.00	5.90	1.39	-	0.93	0.133	0.787 (20mm)			HH5X25				
	0.984 (25mm)	0.787 (20mm)	KGD <sup>R/L</sup> 16-4T25	●	●	1.00	-	0.374	1.00	5.90	1.59	-	0.93	0.133			0.984 (25mm)	0.157 (4mm)	0.197 (5mm)	HH5X25	LW-4
0.197 (5mm)	0.394 (10mm)	KGD <sup>R/L</sup> 12-5T10	●	●	0.75	-	0.374	0.75	4.92	1.20	-	0.66	0.173	0.394 (10mm)	0.197 (5mm)	0.236 (6mm)	HH5X16	LW-4			
		16-5T10	●	●	1.00	-	0.374	1.00	5.90	1.20	-	0.91	0.173	0.394 (10mm)			HH5X25				
	0.669 (17mm)	KGD <sup>R/L</sup> 12-5T17	●	●	0.75	-	0.374	0.75	4.92	1.47	-	0.66	0.173	0.669 (17mm)			0.197 (5mm)	0.236 (6mm)	HH5X16	LW-4	
		16-5T17	●	●	1.00	-	0.374	1.00	5.90	1.47	-	0.91	0.173	0.669 (17mm)					HH5X25		
	0.984 (25mm)	0.669 (17mm)	KGD <sup>R/L</sup> 16-5T25	●	●	1.00	-	0.374	1.00	5.90	1.59	-	0.91	0.173			0.984 (25mm)	0.197 (5mm)	0.236 (6mm)	HH5X25	LW-4
0.236 (6mm)	0.591 (15mm)	KGD <sup>R/L</sup> 16-6T15	●	●	1.00	-	0.374	1.00	5.90	1.28	-	0.89	0.208	0.590 (15mm)	0.236 (6mm)	0.236 (6mm)	HH5X25	LW-4			
	1.181 (30mm)	KGD <sup>R/L</sup> 16-6T30	●	●	1.00	-	0.374	1.00	5.90	1.79	-	0.89	0.208	1.181 (30mm)			HH5X25				
0.315 (8mm)	0.984 (25mm)	KGD <sup>R/L</sup> 16-8T25	●	●	1.00	0.26	0.374	1.00	5.90	1.65	1.69	0.89	0.236	0.984 (25mm)	0.315 (8mm)	0.315 (8mm)	HH6X25	LW-5			

Note 1) Dimension T\* : Shows the maximum grooving depth. If the dimension T is 0.787" (20mm) or more, using a 2-edge insert, the maximum grooving depth is 0.709" (18mm).  
 2) Recommended tightening torque for clamp bolt is 6.5Nm for HH5X○○ and 8.0Nm for HH6X25.  
 3) Above toolholders can also be used for cut-off applications.

Choose an insert with a width that falls within the MIN and MAX parameters shown in table above.  
 Applicable Inserts See [Page 4-6](#)

● : U.S. Stock

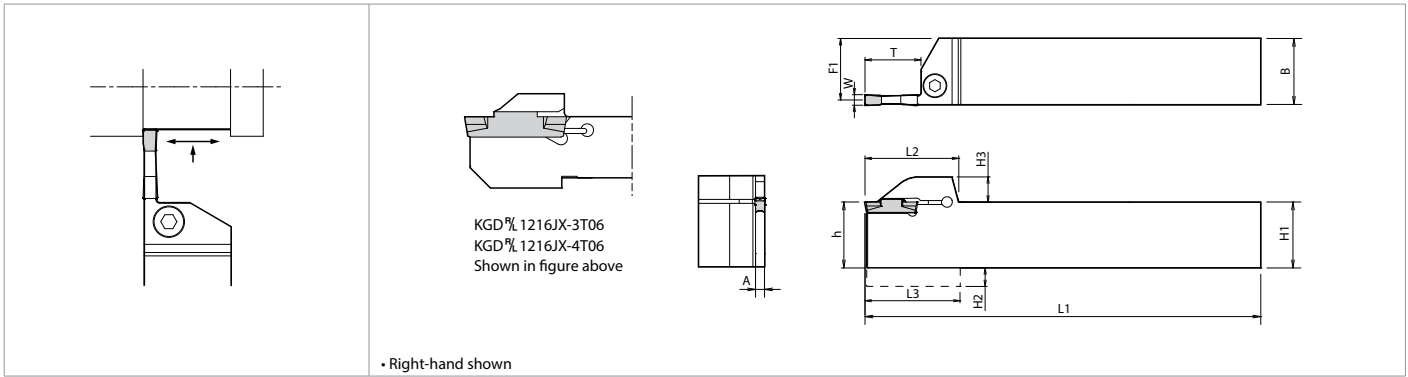

Toolholder Dimensions (Metric Size)

Width (mm)	Max. Grooving Depth (mm)	Part Number	Stock		Dimensions (mm)										Insert Width W (mm)		Spare Parts					
					R	L	H1=h	H2	H3	B	L1	L2	L3	F1			A	T*	MIN	MAX	Clamp Screw/Bolt	Wrench
2.0	6	KGD 1616H-2T06	○	○	16	4.0	9.5	16	100	27.7	28.0	15.2	1.7	6	2.0	3.0	HH5X16	LW-4				
		KGD 2020K-2T06	○	○	20	-	9.5	20	125	28.0	-	19.2					HH5X16					
		KGD 2525M-2T06	○	○	25	-	9.5	25	150	28.0	-	24.2					HH5X25					
	KGD 1616H-2T10	○	○	16	4.0	9.5	16	100	30.2	30.5	15.2	HH5X16					LW-4					
	KGD 2020K-2T10	○	○	20	-	9.5	20	125	30.5	-	19.2	HH5X16										
	KGD 2525M-2T10	○	○	25	-	9.5	25	150	30.5	-	24.2	HH5X25										
	17	KGD 1616H-2T17	○	○	16	4.0	9.5	16	100	31.2	31.5	15.2		17	17	17	2.0	3.0	HH5X16	LW-4		
		KGD 2012K-2T17	○	○	20	-	9.5	12	125	32.5	-	11.2							HH5X16			
		KGD 2020K-2T17	○	○	20	-	9.5	20	125	32.5	-	19.2							HH5X16			
	2.4	17	KGD 2525M-2T17	○	○	25	-	9.5	25	150	32.5	-		24.2	2.0	17	17	2.4	3.0	HH5X25	LW-4	
			KGD 2012K-2.4T17	○	○	20	-	9.5	12	125	32.5	-		11.0						HH5X16		
			KGD 2020K-2.4T17	○	○	20	-	9.5	20	125	32.5	-		19.0						HH5X16		
3.0	6	KGD 1216JX-3T06	○	○	12	2.0	5.5	16	120	19.5	19.0	14.8	2.4	6	3.0	4.0	SE-50125TR	LTW-20				
		KGD 1616H-3T06	○	○	16	4.0	9.5	16	100	27.7	28.0	14.8					HH5X16					
		KGD 2020K-3T06	○	○	20	-	9.5	20	125	28.0	-	18.8					HH5X16					
		KGD 2525M-3T06	○	○	25	-	9.5	25	150	28.0	-	23.8					HH5X25					
	KGD 1616H-3T10	○	○	16	4.0	9.5	16	100	30.2	30.5	14.8	HH5X16					LW-4					
	KGD 2020K-3T10	○	○	20	-	9.5	20	125	30.5	-	18.8	HH5X16										
	10	KGD 2525M-3T10	○	○	25	-	9.5	25	150	30.5	-	23.8		10	10	3.0	4.0	HH5X25	LW-4			
		KGD 1616H-3T20	○	○	16	4.0	9.5	16	100	34.2	34.5	14.8						HH5X16				
		KGD 2012K-3T20	○	○	20	-	9.5	12	125	34.5	-	10.8						HH5X16				
		KGD 2020K-3T20	○	○	20	-	9.5	20	125	34.5	-	18.8						HH5X16				
	20	KGD 2525M-3T20	○	○	25	-	9.5	25	150	35.5	-	23.8		20	20	20	3.0	4.0	HH5X25	LW-4		
		KGD 1616H-3T20	○	○	16	4.0	9.5	16	100	34.2	34.5	14.8							HH5X16			
KGD 2012K-3T20		○	○	20	-	9.5	12	125	34.5	-	10.8	HH5X16										
KGD 2020K-3T20		○	○	20	-	9.5	20	125	34.5	-	18.8	HH5X16										
4.0	6	KGD 2525M-3T20	○	○	25	-	9.5	25	150	35.5	-	23.8	3.4	6	4.0	5.0	HH5X25	LW-4				
		KGD 1216JX-4T06	○	○	12	2.0	5.5	16	120	19.5	19.0	14.3					SE-50125TR					
	10	KGD 2020K-4T10	○	○	20	-	9.5	20	125	30.5	-	18.3		10	10	4.0	5.0	HH5X16	LW-4			
		KGD 2525M-4T10	○	○	25	-	9.5	25	150	30.5	-	23.3						HH5X25				
		KGD 2020K-4T20	○	○	20	-	9.5	20	125	34.5	-	18.3						HH5X16				
20	KGD 2525M-4T20	○	○	25	-	9.5	25	150	35.5	-	23.3	20	20	4.0	5.0	HH5X25	LW-4					
	KGD 2525M-4T25	○	○	25	-	9.5	25	150	40.5	-	23.3					HH5X25						
5.0	10	KGD 2525M-4T25	○	○	25	-	9.5	25	150	40.5	-	23.3	4.4	10	5.0	6.0	HH5X25	LW-4				
		KGD 2020K-5T10	○	○	20	-	9.5	20	125	30.5	-	17.8					HH5X16					
	KGD 2525M-5T10	○	○	25	-	9.5	25	150	30.5	-	22.8	HH5X25										
	KGD 2020K-5T17	○	○	20	-	9.5	20	125	37.5	-	17.8	HH5X16										
17	KGD 2525M-5T17	○	○	25	-	9.5	25	150	37.5	-	22.8	17	17	5.0	6.0	HH5X25	LW-4					
	KGD 2020K-5T17	○	○	20	-	9.5	20	125	37.5	-	17.8					HH5X16						
	KGD 2525M-5T25	○	○	25	-	9.5	25	150	40.5	-	22.8					HH5X25						
25	KGD 2020K-5T25	○	○	20	-	9.5	20	125	37.5	-	17.8	25	25	5.0	6.0	HH5X25	LW-4					
	KGD 2525M-5T25	○	○	25	-	9.5	25	150	40.5	-	22.8					HH5X25						
6.0	15	KGD 2525M-6T15	○	○	25	-	9.5	25	150	32.5	-	22.4	5.3	15	6.0	6.0	HH5X25	LW-4				
	30	KGD 2525M-6T30	○	○	25	-	9.5	25	150	45.5	-	22.4					30		HH5X25			
8.0	25	KGD 2525M-8T25	○	○	25	7.0	9.5	25	150	43.3	44.2	22.0	6.0	25	8.0	8.0	HH6X25	LW-5				
		KGD 3232P-8T25	○	○	32	-	9.5	32	170	43.3	-	29.0					HH6X25					

Note 1) Dimension T\*: Shows the maximum grooving depth. If the dimension T is 0.787" (20mm) or more, using a 2-edge insert, the maximum grooving depth is 0.709" (18mm).

2) Recommended tightening torque for clamp bolt/screw is 6.5Nm for HH5X○○, 8.0Nm for HH6X25 and 2.5Nm for SE-50125TR.

3) Above toolholders can also be used for cut-off applications.

Choose an insert with a width that falls within the MIN and MAX parameters shown in table above.

○ : World Express (Shipping: 7-10 Business Days)

Applicable Inserts See [Page 4-6](#)

# KGD-S | 0° SwitchBlade (Inch Size)

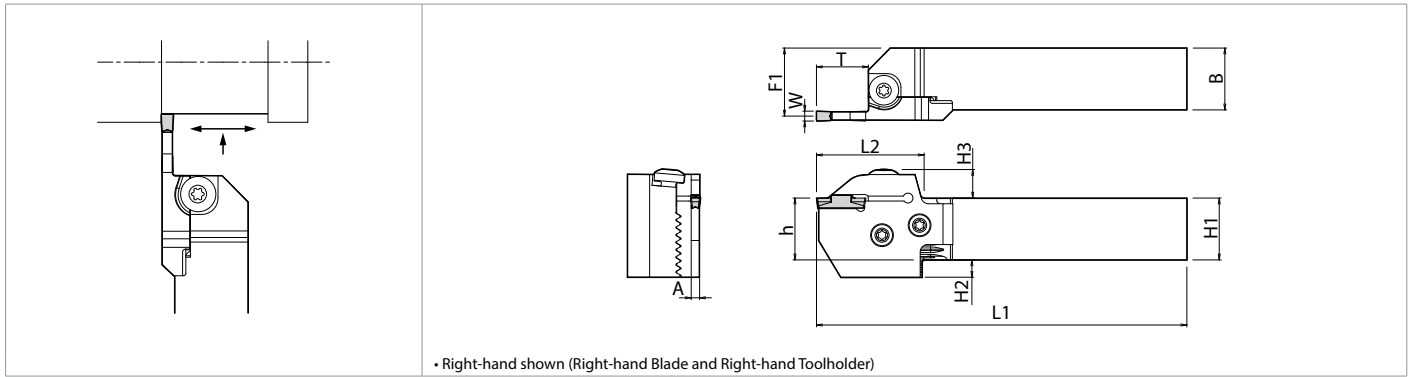

## Toolholder + Blade Dimensions (Inch Size)

Shank Angle	Width (in)	Max. Grooving Depth (in)	Shank Size (in)	Unit Part Number (Toolholder + Blade)	Stock		Toolholder Part Number P13	Blade Part Number P13	Dimensions (in)								Insert Width W (in)			
					R	L			H1=h	H2	H3	B	L1	L2	F1	A	T*	MIN.	MAX.	
0°	0.079 (2mm)	0.669 (17mm)	0.75	KGD P/L 12X-2T17S	●	●	KGD P/L 12-C	KGD P/L -2T17-C	0.75	0.472	0.456	0.75	4.80	1.57	0.88	0.067	0.669 (17mm)	0.079 (2mm)	0.118 (3mm)	
			1.00	16X-2T17S	●	●	KGD P/L 16-C		1.00	0.276	0.456	1.00	5.78	1.57	1.13					
	0.118 (3mm)	0.394 (10mm)	0.394 (10mm)	0.75	KGD P/L 12X-3T10S	●	●	KGD P/L 12-C	KGD P/L -3T10-C	0.75	0.472	0.456	0.75	4.52	1.29	0.86	0.094	0.394 (10mm)	0.118 (3mm)	0.157 (4mm)
				1.00	16X-3T10S	●	●	KGD P/L 16-C		1.00	0.276	0.456	1.00	5.51	1.29	1.11				
		0.787 (20mm)	0.787 (20mm)	0.75	KGD P/L 12X-3T20S	●	●	KGD P/L 12-C	KGD P/L -3T20-C	0.75	0.472	0.456	0.75	4.92	1.68	0.86				
				1.00	16X-3T20S	●	●	KGD P/L 16-C		1.00	0.276	0.456	1.00	5.90	1.68	1.11				
	0.157 (4mm)	0.394 (10mm)	0.394 (10mm)	0.75	KGD P/L 12X-4T10S	●	●	KGD P/L 12-C	KGD P/L -4T10-C	0.75	0.472	0.456	0.75	4.52	1.29	0.84	0.133	0.394 (10mm)	0.157 (4mm)	0.197 (5mm)
				1.00	16X-4T10S	●	●	KGD P/L 16-C		1.00	0.276	0.456	1.00	5.51	1.29	1.09				
		0.787 (20mm)	0.787 (20mm)	0.75	KGD P/L 12X-4T20S	●	●	KGD P/L 12-C	KGD P/L -4T20-C	0.75	0.472	0.456	0.75	4.92	1.68	0.84				
				1.00	16X-4T20S	●	●	KGD P/L 16-C		1.00	0.276	0.456	1.00	5.90	1.68	1.09				
		0.984 (25mm)	0.984 (25mm)	0.984 (25mm)	0.75	KGD P/L 12X-4T25S	●	●	KGD P/L 12-C	KGD P/L -4T25-C	0.75	0.472	0.456	0.75	5.11	1.88		0.84		
					1.00	16X-4T25S	●	●	KGD P/L 16-C		1.00	0.276	0.456	1.00	6.10	1.88		1.09		
0.197 (5mm)	0.394 (10mm)	0.394 (10mm)	0.75	KGD P/L 12X-5T10S	●	●	KGD P/L 12-C	KGD P/L -5T10-C	0.75	0.472	0.456	0.75	4.52	1.29	0.82	0.173	0.394 (10mm)	0.197 (5mm)	0.236 (6mm)	
			1.00	16X-5T10S	●	●	KGD P/L 16-C		1.00	0.276	0.456	1.00	5.51	1.29	1.07					
	0.984 (25mm)	0.984 (25mm)	0.984 (25mm)	1.00	KGD P/L 16X-5T25S	●	●	KGD P/L 16-C	KGD P/L -5T25-C	1.00	0.276	0.456	1.00	6.10	1.88		1.07			

- Note 1) When using the toolholder in normal mounting position, the lower jaw of the toolholder may interfere with the tool presetter.  
 2) The toolholder and blade part numbers are printed on the toolholder body. (Unit part numbers are not printed)  
**KGD-S: Right-hand blades for right-hand toolholders, and left-hand blades for left-hand toolholders.**  
 3) If the unit part number is not listed (No Unit Part Number), please purchase toolholder and blade separately.  
 4) Dimension T\*: Shows the maximum grooving depth. If the dimension T is 0.787" (20mm) or more, using a 2-edge insert, the maximum grooving depth is 0.709" (18mm).

Choose an insert with a width that falls within the MIN and MAX parameters shown in table above.  
 Applicable Inserts See [Page 4-6](#)

● : U.S. Stock

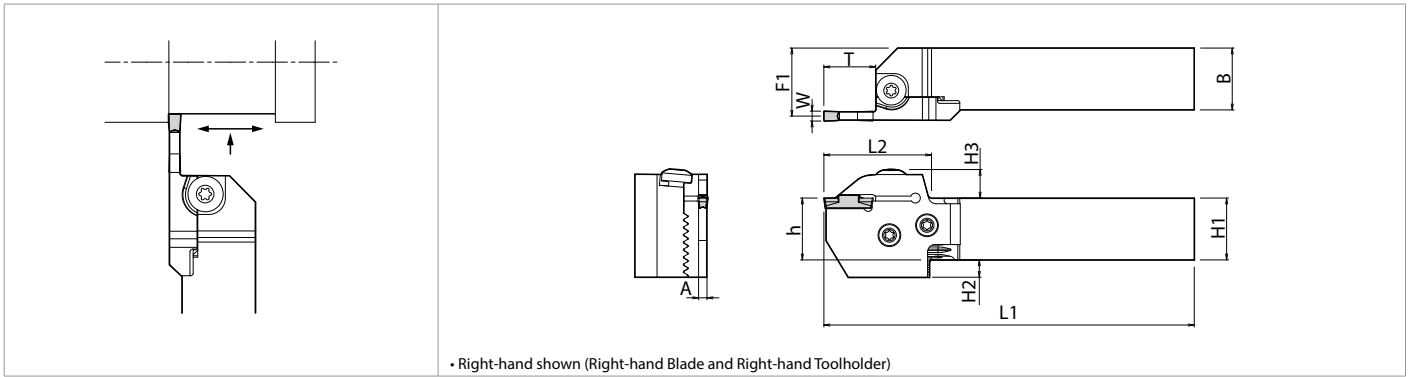

Toolholder + Blade Dimensions (Metric Size)

Shank Angle	Width (mm)	Max. Grooving Depth (mm)	Shank Size (mm)	Unit Part Number (Toolholder + Blade)	Stock		Toolholder Part Number P13	Blade Part Number P13	Dimensions (mm)										Insert Width W (mm)	
					R	L			H1=h	H2	H3	B	L1	L2	F1	A	T*	MIN.	MAX.	
0°	2	17	□20	KGD P/L 2020X-2T17S	○	○	KGD P/L 2020-C	KGD P/L -2T17-C	20	12	11.6	20	122	40	23.4	1.7	17	2.0	3.0	
			□25	2525X-2T17S	○	○	KGD P/L 2525-C		25	7	11.6	25	147	40	28.4					
			□32	No Unit Part Number →	○	○	KGD P/L 3232-C		32	-	11.6	32	167	40	35.4					
	3	10	□20	KGD P/L 2020X-3T10S	○	○	KGD P/L 2020-C	KGD P/L -3T10-C	20	12	11.6	20	115	33	23.0	2.4	10	3.0	4.0	
			□25	2525X-3T10S	○	○	KGD P/L 2525-C		25	7	11.6	25	140	33	28.0					
			□32	3232X-3T10S	○	○	KGD P/L 3232-C		32	-	11.6	32	160	33	35.0					
		20	□20	KGD P/L 2020X-3T20S	○	○	KGD P/L 2020-C	KGD P/L -3T20-C	20	12	11.6	20	125	43	23.0					
			□25	2525X-3T20S	○	○	KGD P/L 2525-C		25	7	11.6	25	150	43	28.0					
			□32	3232X-3T20S	○	○	KGD P/L 3232-C		32	-	11.6	32	170	43	35.0					
	4	10	□20	KGD P/L 2020X-4T10S	○	○	KGD P/L 2020-C	KGD P/L -4T10-C	20	12	11.6	20	115	33	22.5	3.4	20	4.0	5.0	
			□25	2525X-4T10S	○	○	KGD P/L 2525-C		25	7	11.6	25	140	33	27.5					
			□32	3232X-4T10S	○	○	KGD P/L 3232-C		32	-	11.6	32	160	33	34.5					
		20	□20	KGD P/L 2020X-4T20S	○	○	KGD P/L 2020-C	KGD P/L -4T20-C	20	12	11.6	20	125	43	22.5					
			□25	2525X-4T20S	○	○	KGD P/L 2525-C		25	7	11.6	25	150	43	27.5					
			□32	3232X-4T20S	○	○	KGD P/L 3232-C		32	-	11.6	32	170	43	34.5					
		25	□20	KGD P/L 2020X-4T25S	○	○	KGD P/L 2020-C	KGD P/L -4T25-C	20	12	11.6	20	130	48	22.5					
			□25	2525X-4T25S	○	○	KGD P/L 2525-C		25	7	11.6	25	155	48	27.5					
			□32	3232X-4T25S	○	○	KGD P/L 3232-C		32	-	11.6	32	175	48	34.5					
	5	10	□20	KGD P/L 2020X-5T10S	○	○	KGD P/L 2020-C	KGD P/L -5T10-C	20	12	11.6	20	115	33	22.0	4.4	10	5.0	6.0	
			□25	2525X-5T10S	○	○	KGD P/L 2525-C		25	7	11.6	25	140	33	27.0					
			□32	3232X-5T10S	○	○	KGD P/L 3232-C		32	-	11.6	32	160	33	34.0					
		25	□20	KGD P/L 2020X-5T25S	○	○	KGD P/L 2020-C	KGD P/L -5T25-C	20	12	11.6	20	130	48	22.0					
			□25	2525X-5T25S	○	○	KGD P/L 2525-C		25	7	11.6	25	155	48	27.0					
			□32	3232X-5T25S	○	○	KGD P/L 3232-C		32	-	11.6	32	175	48	34.0					

Note 1) When using the toolholder in normal mounting position, the lower jaw of the toolholder may interfere with the tool presetter.

2) The toolholder and blade part numbers are printed on the toolholder body. (Unit part numbers are not printed)

**KGD-S: Right-hand blades for right-hand toolholders, and left-hand blades for left-hand toolholders.**

3) If the unit part number is not listed (No Unit Part Number), please purchase toolholder and blade separately.

4) Dimension T\*: Shows the maximum grooving depth. If the dimension T is 0.787" (20mm) or more, using a 2-edge insert, the maximum grooving depth is 0.709" (18mm).

Choose an insert with a width that falls within the MIN and MAX parameters shown in table above.

○ : World Express (Shipping: 7-10 Business Days)

Applicable Inserts See [Page 4-6](#)



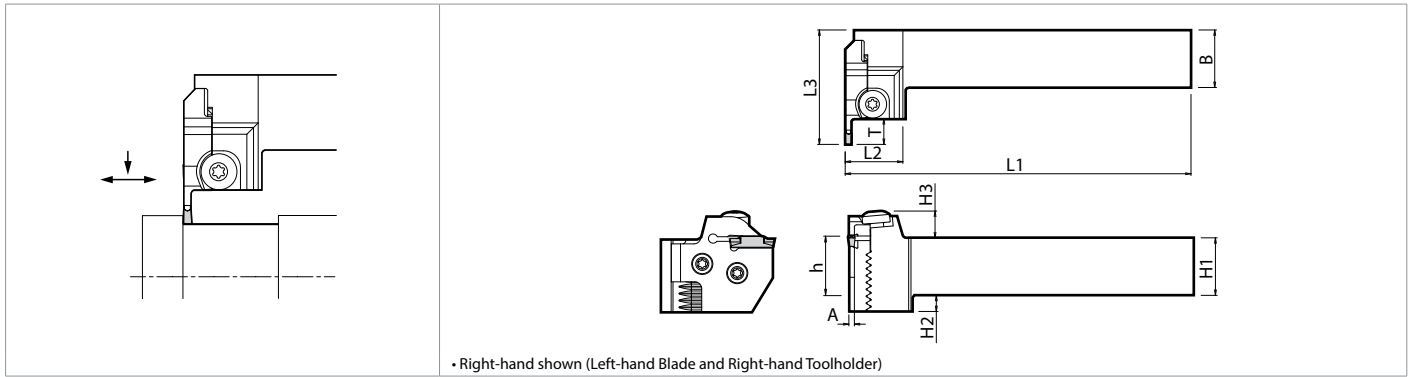

Toolholder + Blade Dimensions (Metric Size)

Shank Angle	Width (mm)	Max. Grooving Depth (mm)	Shank Size (mm)	Unit Part Number (Toolholder + Blade)	Stock		Toolholder Part Number P13	Blade Part Number P13	Dimensions (mm)										Insert Width W (mm)										
					R	L			H1=h	H2	H3	B	L1	L2	L3	A	T*	MIN.	MAX.										
90°	2	17	□20	No Unit Part Number ➔			KGDS 2020-C	KGD 2T17-C	20	12	11.6	20	125	27.7	56.7	1.7	17	2.0	3.0										
			□25				KGDS 2525-C	KGD 2T17-C	25	7	11.6	25	150	27.7	56.7														
	3	10	□20	KGDS 2020X-3T10S	○	○	KGDS 2020-C	KGD 3T10-C	20	12	11.6	20	125	27.7	49.7	2.4	10	3.0	4.0										
			□25	2525X-3T10S	○	○	KGDS 2525-C	KGD 3T10-C	25	7	11.6	25	150	27.7	49.7														
		20	□20	No Unit Part Number ➔				KGDS 2020-C	KGD 3T20-C	20	12	11.6	20	125	27.7					59.7									
			□25					KGDS 2525-C	KGD 3T20-C	25	7	11.6	25	150	27.7					59.7									
	4	10	□20	No Unit Part Number ➔				KGDS 2020-C	KGD 4T10-C	20	12	11.6	20	125	27.7	49.7	3.4	10	4.0	5.0									
			□25					KGDS 2525-C	KGD 4T10-C	25	7	11.6	25	150	27.7	49.7													
		20	□20					KGDS 2020-C	KGD 4T20-C	20	12	11.6	20	125	27.7	59.7													
			□25					KGDS 2525-C	KGD 4T20-C	25	7	11.6	25	150	27.7	59.7													
		25	□20					KGDS 2020-C	KGD 4T25-C	20	12	11.6	20	125	27.7	64.7													
			□25					KGDS 2525-C	KGD 4T25-C	25	7	11.6	25	150	27.7	64.7													
		5	10					□20	No Unit Part Number ➔				KGDS 2020-C	KGD 5T10-C	20	12					11.6	20	125	27.7	49.7	4.4	10	5.0	6.0
								□25					KGDS 2525-C	KGD 5T10-C	25	7					11.6	25	150	27.7	49.7				
	25		□20	KGDS 2020-C	KGD 5T25-C	20	12	11.6					20	125	27.7	64.7													
			□25	KGDS 2525-C	KGD 5T25-C	25	7	11.6					25	150	27.7	64.7													

Note 1) When using the toolholder in normal mounting position, the lower jaw of the toolholder may interfere with the tool presetter.

2) The toolholder and blade part numbers are printed on the toolholder body. (Unit part numbers are not printed)

KGDS-S: Left-hand blades for right-hand toolholders, and right-hand blades for left-hand toolholders.

3) If the unit part number is not listed (No Unit Part Number), please purchase toolholder and blade separately.

4) Dimension T\*: Shows the maximum grooving depth. If the dimension T is 0.787" (20mm) or more, using a 2-edge insert, the maximum grooving depth is 0.709" (18mm).

Choose an insert with a width that falls within the MIN and MAX parameters shown in table above.

○ : World Express (Shipping: 7-10 Business Days)

Applicable Inserts See [Page 4-6](#)

## KGD

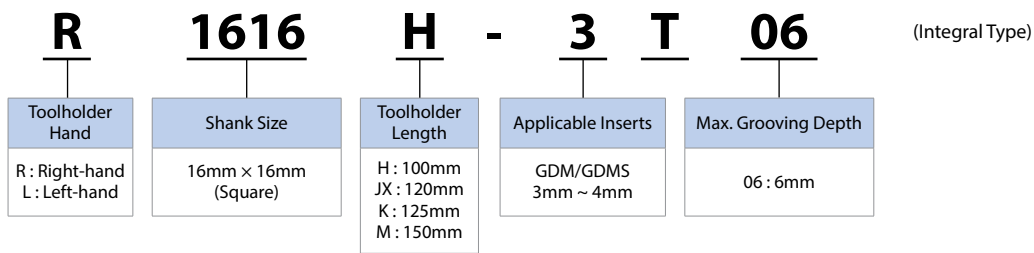

## KGD KGDS

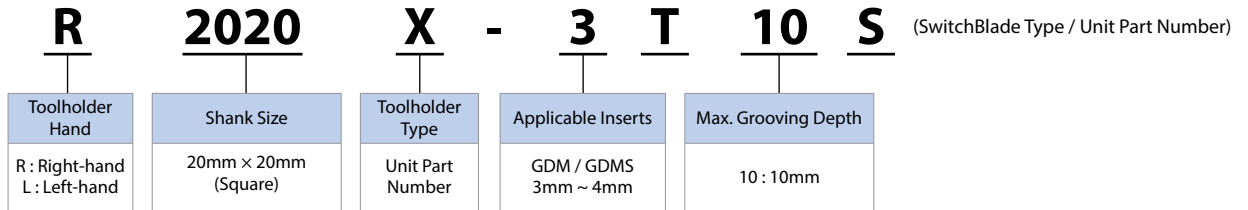

## SwitchBlade Toolholder Unit Structure (External Grooving, Cut-Off)

### 1) 0° SwitchBlade Type

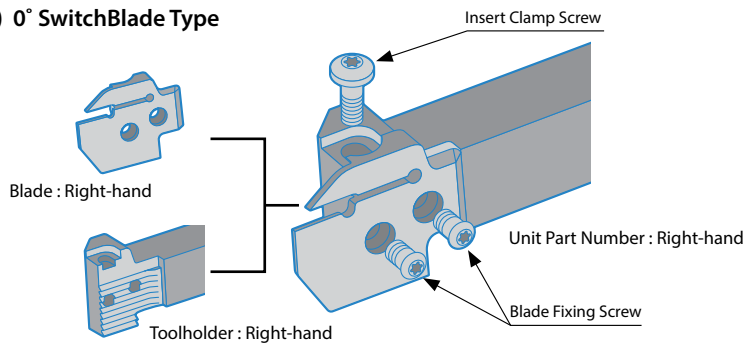

Toolholder (KGD<sup>ℓ</sup>○○-C)  
+  
Blade (KGD<sup>ℓ</sup>-○○○○-C)

⇒ Right-hand Blade for Right-hand Toolholder,  
Left-hand Blade for Left-hand Toolholder.

### 2) 90° SwitchBlade Type

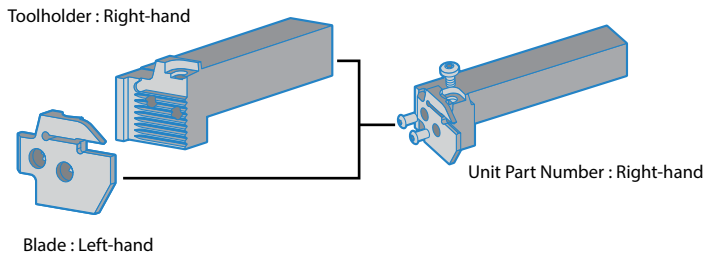

Toolholder (KGDS<sup>ℓ</sup>○○-C)  
+  
Blade (KGD<sup>ℓ</sup>-○○○○-C)

⇒ Left-hand Blade for Right-hand Toolholder,  
Right-hand Blade for Left-hand Toolholder.

## SwitchBlade Toolholder Identification System and Lathe Setting

Firmly fit the lower jaw to the tool post of the lathe.

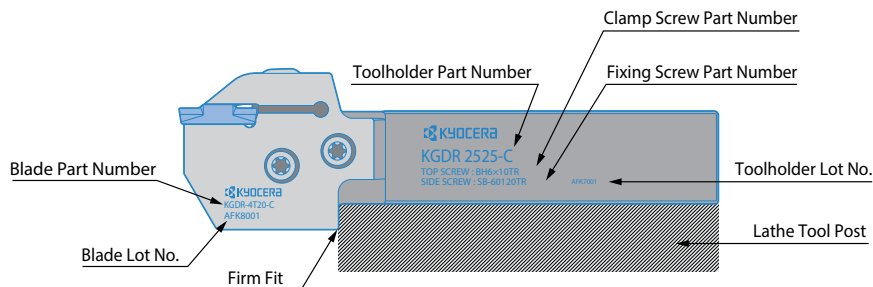

# Toolholders & Blades (for Grooving, Cut-Off)

## Toolholder Dimensions

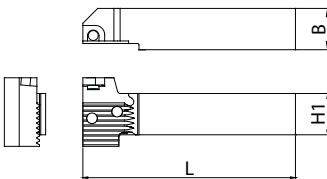
KGD-S (0° SwitchBlade Type) Right-hand shown	Toolholder Part Number	Stock		Unit	Dimensions		
		R	L		L	B	H1
	KGD <sup>®</sup> /L 12-C	●	●	inch	4.09	0.75	0.75
		●	●		5.08	1.00	1.00
	KGD <sup>®</sup> /L 2020-C	○	○	mm	104	20	20
		○	○		129	25	25
	3232-C	○	○		149	32	32

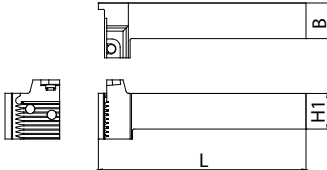

KGDS-S (90° SwitchBlade Type) Right-hand shown	Toolholder Part Number	Stock		Unit	Dimensions		
		R	L		L	B	H1
	KGDS <sup>®</sup> /L 12-C	●	●	inch	4.80	0.75	0.75
		●	●		5.79	1.00	1.00
	KGDS <sup>®</sup> /L 2020-C	○	○	mm	122	20	20
		○	○		147	25	25

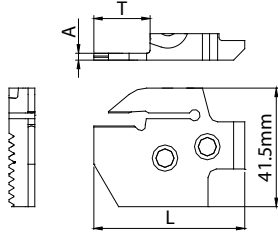
## Blade Dimensions

Blade Right-hand shown	Blade Part Number	Stock		Unit	Dimensions		
		R	L		L	T	A
	KGD <sup>®</sup> /L	●	●	mm	51.2	17.2	1.7
		●	●		44.2	10.2	2.4
		●	●		53.2	20.2	2.4
		●	●		44.2	10.2	3.4
		●	●		54.2	20.2	3.4
		●	●		59.2	25.2	3.4
		○	●		44.2	10.2	4.4
		●	●		59.2	25.2	4.4

● : U.S. Stock ○ : World Express (Shipping: 7-10 Business Days)

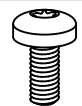
## Spare Parts (Common with SwitchBlade Types)

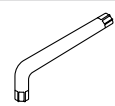
Unit Part Number	Spare Parts		
	Clamp Screw (for Insert Clamp)	Clamp Screw (for Blade)	Wrench
			
KGD <sup>®</sup> /L .....S KGDS <sup>®</sup> /L .....S	BH6X10TR	SB-60120TR	LTW-25

\* Parts are included with the toolholder and unit.

## Setting the Blade Into the Toolholder (SwitchBlade Type)

1. Use compressed air or other measures to remove chips and dust from the serrated surface. (See Fig.1)
2. Mate and fit the serrations of the blade and toolholder, and also fit the blade end to the toolholder. (See Fig.2)
3. Tighten the blade fixing screws at an appropriate torque. You can tighten them in any order. (See Fig.2) (Recommended tightening torque : 8Nm)
4. Set the insert after setting the blade. (See Page 6 for insert setting instructions)

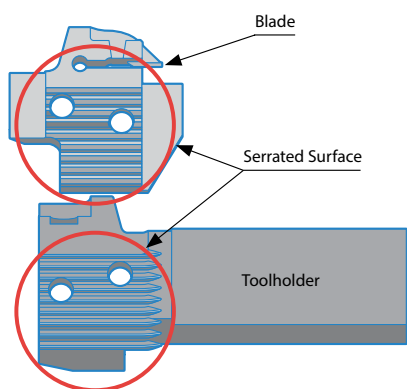

Fig.1

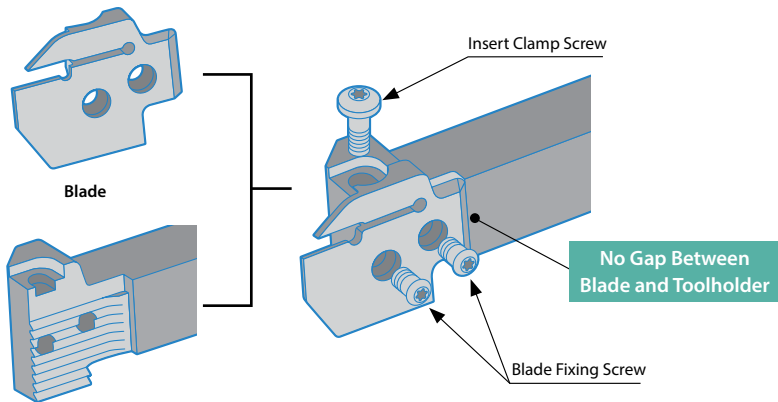
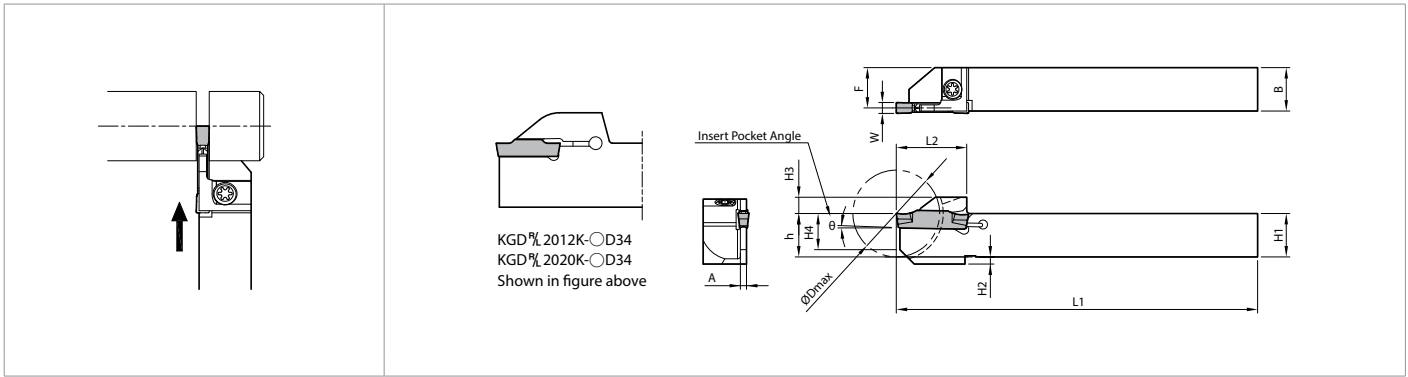



Fig.2



Toolholder Dimensions (Inch Size)

Part Number	Stock		Cut-Off Dia. (in)	Dimensions (in)										Insert Width W (in)		Spare Parts			
	R	L		H1=h	H2	H3	H4	B	L1	L2	F	A	θ	MIN.	MAX.				
																		ØDmax	
KGD% 6-1.5JX	●	●	0.787	0.375	0.098	0.177	0.315	0.375	4.75	0.709	0.351	0.047	1°	-	0.059	SB-40120TR	LTW-15S		
8-1.5JX	●	●	0.944	0.500	0.051	0.177	0.394	0.500	4.75	0.768	0.476								
KGD% 6-2JX	●	●	0.787	0.375	0.098	0.177	0.315	0.375	4.75	0.709	0.342	0.067	1°	0.079	0.118				
8-2JX	●	●	0.944	0.500	0.051	0.177	0.394	0.500	4.75	0.768	0.467								
10-2JX	●	●	1.259	0.625	-	0.177	0.394	0.625	4.75	0.965	0.592								
KGD% 6-2.4JX	●	●	0.787	0.375	0.098	0.177	0.315	0.375	4.75	0.709	0.336	0.079	1°	0.094	0.118				
8-2.4JX	●	●	0.944	0.500	0.051	0.177	0.394	0.500	4.75	0.768	0.461								
10-2.4JX	●	●	1.259	0.625	-	0.177	0.394	0.625	4.75	0.965	0.586								
KGD% 8-3JX	●	●	0.944	0.500	0.051	0.177	0.394	0.500	4.75	0.768	0.453	0.094	1°	0.118	0.118				
10-3JX	●	●	1.259	0.625	-	0.177	0.394	0.625	4.75	0.965	0.578							0.157	
KGD% 10-3D38JX	●	●	1.496	0.625	-	0.236	0.394	0.625	4.75	1.142	0.578	0.094	1°	0.118	0.157			SE-50125TR	LTW-20
12-3D42JX	●	●	1.653	0.750	-	0.236	0.551	0.750	4.75	1.220	0.703								
43-3D42JX	●	●	1.653	0.750	-	0.236	0.551	0.500	4.75	1.220	0.453								

- Note 1) 0.157" (4mm) width insert can be installed in KGD% 8-3JX, but is not recommended due to the toolholder's rigidity.  
 2) Recommended tightening torque for clamp screw is 2.0Nm for SB-40120TR and 2.5Nm for SE-50125TR.  
 3) When machining material greater than Ø1.417" (36mm) with KGD% 10-3D38JX, KGD% 12-3D42JX, or KGD% 43-3D42JX toolholders, use 1-edge inserts.  
 Max. workpiece diameter for 2-edge inserts is Ø1.417" (36mm)

Choose an insert with a width that falls within the MIN and MAX parameters shown in table above.  
 Applicable Inserts See [Page 4-6](#)

● : U.S. Stock

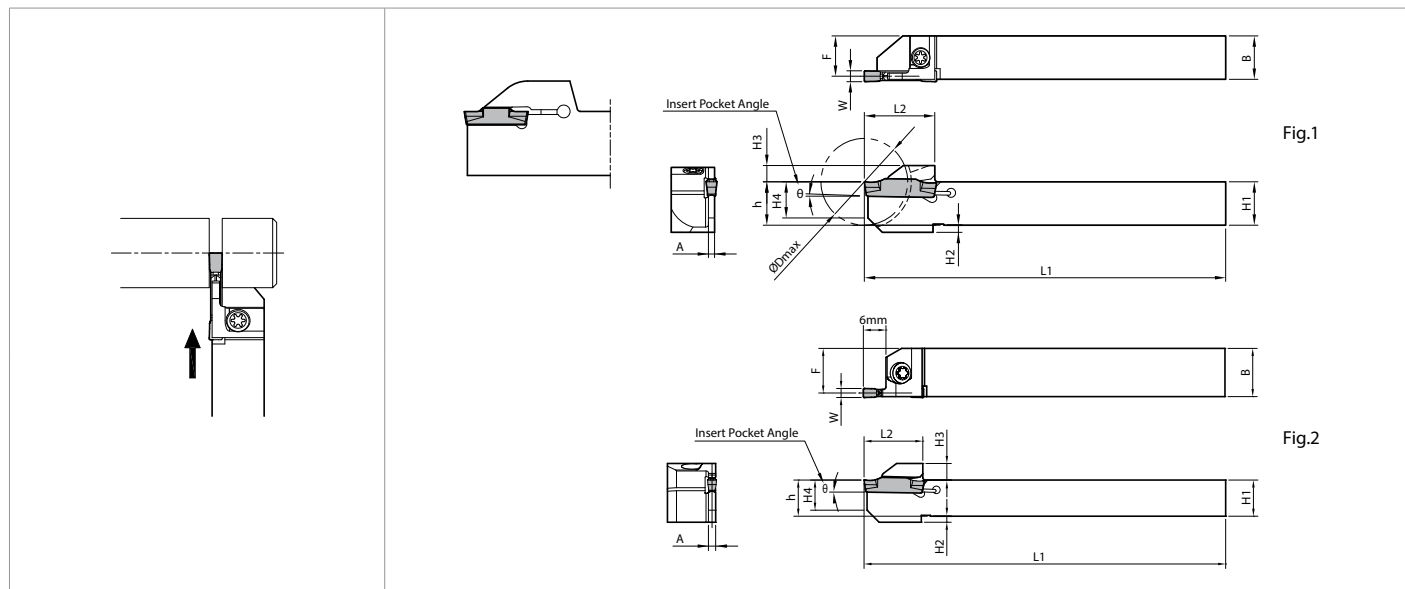

Toolholder Dimensions (Metric Size)

Part Number	Stock		Cut-Off Dia. (mm)	Dimensions (mm)										Insert Width W (mm)		Drawing	Spare Parts	
	R	L		ØDmax	H1=h	H2	H3	H4	B	L1	L2	F	A	θ	MIN.		MAX.	Screw
KGD% 1010JX-1.3D16	○	○	16	10	2	5.5	8	10	120	18.0	9.9	1.0	5°	1.3	1.3	Fig.1	SB-40120TR	LTW-15S
	○	○	20	10	2	5.5	8	10	120	18.0	9.5							
	○	○	16	12	2	5.5	10	12	85	19.5	11.9							
	○	○	16	12	2	5.5	10	12	120	19.5	11.9							
	○	○	24	12	2	5.5	10	12	85	19.5	11.5							
	○	○	24	12	2	5.5	10	12	120	19.5	11.5							
KGD% 1010JX-1.5D16	○	○	16	10	2	5.5	8	10	120	18.0	9.7	1.2	5°	1.5	1.5	Fig.1	SB-40120TR	LTW-15S
	○	○	20	10	2	5.5	8	10	120	18.0	9.4							
	○	○	16	12	2	5.5	10	12	85	19.5	11.7							
	○	○	16	12	2	5.5	10	12	120	19.5	11.7							
	○	○	24	12	2	5.5	10	12	85	19.5	11.4							
	○	○	24	12	2	5.5	10	12	120	19.5	11.4							
KGD% 1010JX-2	○	○	20	10	2	5.5	8	10	120	18.0	9.2	1.6	1°	2.0	3.0	Fig.1	SB-40120TR	LTW-15S
	○	○	24	12	2	5.5	10	12	85	19.5	11.2							
	○	○	24	12	2	5.5	10	12	120	19.5	11.2							
	○	○	32	16	-	5.5	10	16	120	24.5	15.2							
KGD% 1010JX-2.4	○	○	20	10	2	5.5	8	10	120	18.0	9.0	2.0	1°	2.4	3.0	Fig.1	SB-40120TR	LTW-15S
	○	○	24	12	2	5.5	10	12	85	19.5	11.0							
	○	○	24	12	2	5.5	10	12	120	19.5	11.0							
	○	○	32	16	-	5.5	10	16	120	24.5	15.0							
KGD% 1212JX-3	○	○	24	12	2	5.5	10	12	120	19.5	10.8	2.4	1°	3.0	3.0	Fig.1	SB-40120TR	LTW-15S
	○	○	32	16	-	5.5	10	16	120	24.5	14.8				4.0			
KGD% 1616JX-3D38	○	○	38	16	-	8.0	10	16	120	29.0	14.8	2.4	1°	3.0	4.0	Fig.1	SE-50125TR	LTW- 20
	○	○	38	19	-	8.0	13	13	125	29.0	11.8							
	○	○	42	20	-	8.0	14	12	120	31.0	10.8							
	○	○	51	20	-	8.5	14	12	120	36.0	10.8							
	○	○	42	20	-	8.0	14	20	120	31.0	18.8							
	○	○	51	20	-	8.5	14	20	120	36.0	18.8							
KGD% 1216JX-3T06	○	○	12	12	2	5.5	10	16	120	19.5	14.8	2.4	0°	3.0	4.0	Fig.2	SE-50125TR	LTW- 20
	○	○	12	12	2	5.5	10	16	120	19.5	14.3	3.4		4.0	5.0			

Note 1) 0.157" (4mm) width insert can be installed in KGD% 1212JX-3, but is not recommended due to the toolholder's rigidity.  
 2) Recommended tightening torque for clamp screw is 2.0Nm for SB-40120TR, and 2.5Nm for SE-50125TR.  
 3) When machining material greater than Ø1.417" (36mm) with KGD%...-3D38, KGD%...-3D42, or KGD%...-3D51 toolholders, use 1-edge inserts.  
 Max. workpiece diameter for 2-edge inserts is Ø1.417" (36mm)

Choose an insert with a width that falls within the MIN and MAX parameters shown in table above. ○ : World Express (Shipping: 7-10 Business Days)  
 Applicable Inserts See [Page 4-6](#)

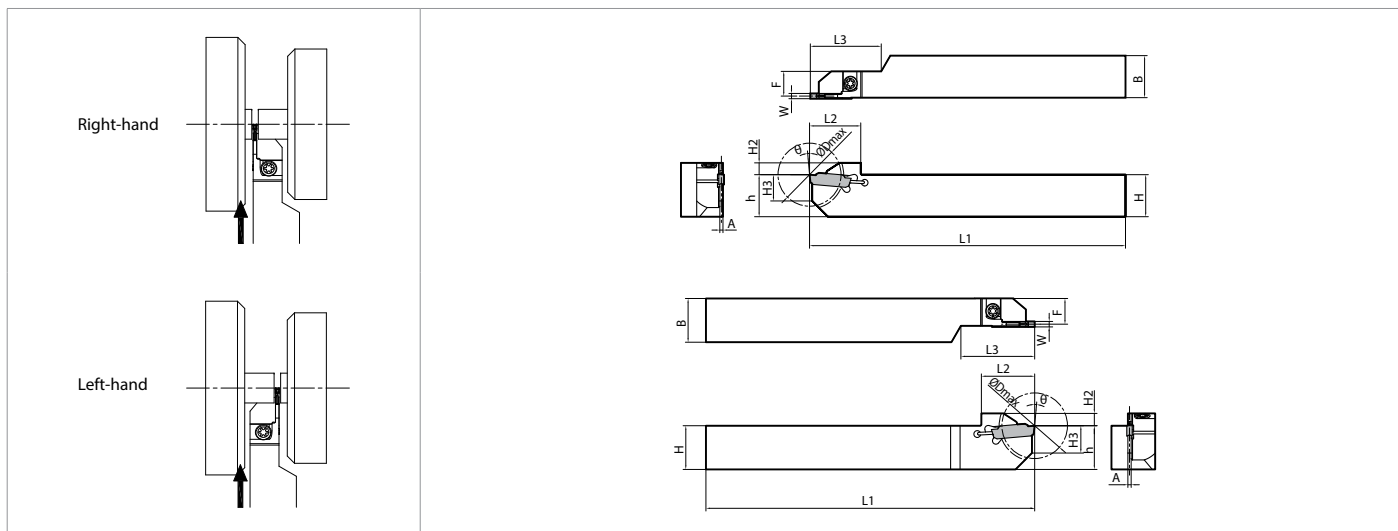

Toolholder Dimensions (Metric Size)

Part Number	Stock		Cut-Off Dia. (mm)	Dimensions (mm)									Angle	Insert Width W (mm)		Spare Parts	
	R	L		ØDmax	H=h	H2	H3	B	L1	L2	L3	F		A	θ	MIN.	MAX.
	KGDS <sup>R/L</sup> 1616JX-1.3B	○	○	24	16	5.5	10	16	120	19.5	27	9.5	1.0	5°	1.3	1.3	SB-40120TR
1616JX-1.5B	○	○	24	16	5.5	10	16	120	19.5	27	9.4	1.2	5°	1.5	1.5		
1616JX-2B	○	○	24	16	5.5	10	16	120	19.5	27	9.2	1.6	1°	2.0	3.0		

Choose an insert with a width that falls within the MIN and MAX parameters shown in table above.

○ : World Express (Shipping: 7-10 Business Days)

Applicable Inserts See [Page 4-6](#)

## Toolholder Identification System (for Small Diameter Cut-Off Holders)

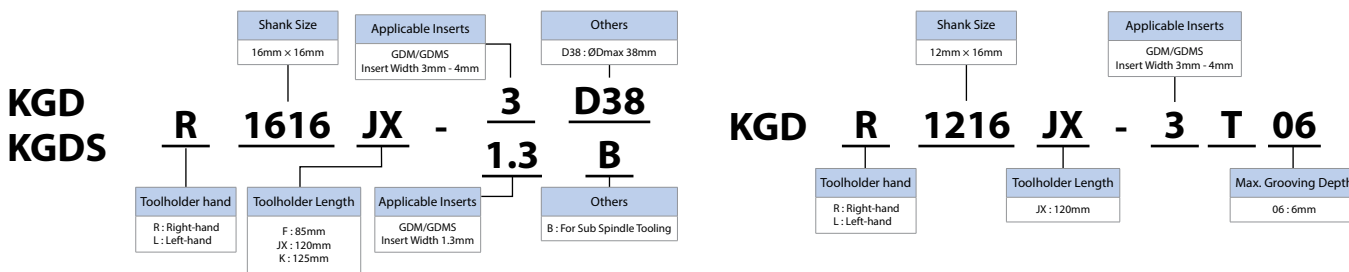

## KGDR / KGDSL Selection Reference

### KGDR Standard Type

Both Right-hand and Left-hand types are applicable to gang tool post.  
Left-hand type is recommended for cut-off operations when using a sub-spindle.

KGDR (Right-hand Toolholder)	KGDL (Left-hand Toolholder)
<b>1st Recommendation</b> Use insert with lead angle to remove boss • Not using sub-spindle • Cut-off operation near main spindle side	<b>1st Recommendation</b> Use insert without lead angle • Using sub-spindle • Cut-off operation near sub-spindle side

### KGDS Sub-Spindle Type

When machining a workpiece with a small diameter, use KGDS to reduce overhang distance from the main spindle.

KGDSR (Right-hand Toolholder)	KGDSL (Left-hand Toolholder)
• Long workpiece and more rigidity • Cut-off operation near main spindle side	• Short workpiece and less rigidity • Cut-off operation near sub-spindle side



# Recommended Cutting Conditions (External Grooving) ★ 1st Recommendation ☆ 2nd Recommendation

Workpiece	Chipbreaker	Recommended Insert Grade (Vc : sfm)								Notes	
		Cermet		MEGACOAT NANO	MEGACOAT		Carbide	MEGACOAT CBN	CBN		PCD
		TN620	TN90	PR1535	PR1225	PR1215	GW15	KBN05M	KBN570		KPD001
Carbon Steel	GM	☆ 260 - 720	☆ 330 - 720	☆ 260 - 660	★ 260 - 660	☆ 330 - 660	-	-	-	-	
Alloy Steel	GL	☆ 230 - 660	☆ 260 - 660	☆ 230 - 590	★ 230 - 590	☆ 260 - 590	-	-	-	-	
Stainless Steel	CM	-	-	★ 200 - 490	☆ 200 - 490	☆ 200 - 490	-	-	-	-	
Cast Iron	PH	-	-	-	-	★ 330 - 660	-	-	-	-	
Aluminum Alloy	GS	-	-	-	-	-	☆ 660 - 1,640	-	-	★ 490 - 6,560	
Brass	NB	-	-	-	-	-	☆ 330 - 660	-	-	★ 660 - 2,620	
Hard Materials	NB	-	-	-	-	-	-	★ 260 - 490	-	-	
Powdered Steel	NB	-	-	-	-	-	-	-	★ 330 - 820	-	

## Recommended Cutting Conditions (Feed Rate / Depth of Cut)

(Workpiece : 1049)

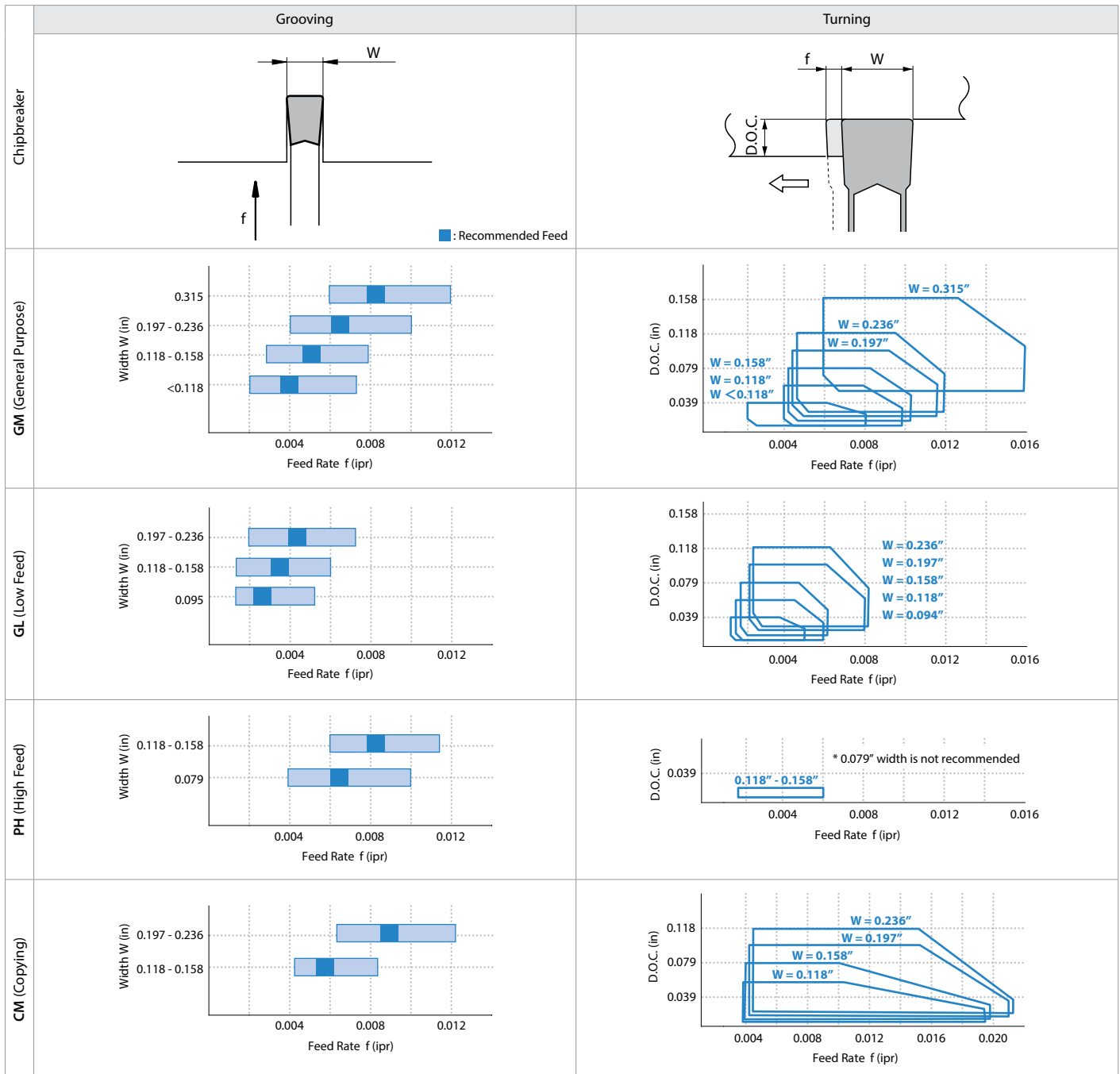

1) The above values reflect a T dimension that is 0.669" (17mm) or less.  
 2) If the toolholder is not for the 0.315" (8mm) width insert and its T dimension is over 0.669" (17mm), set the values for turning to less than 90% of recommended cutting conditions above.

# Recommended Cutting Conditions (External Grooving)

## Recommended Cutting Conditions (Feed Rate / D.O.C.) (Workpiece : 1049)

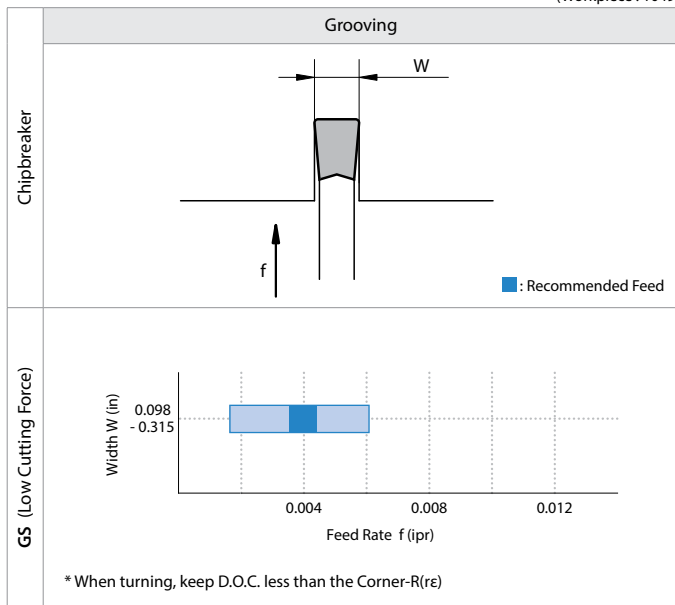

1) The above values reflect a T dimension that is 0.669" (17mm) or less.

## Recommended Cutting Conditions (Feed Rate)

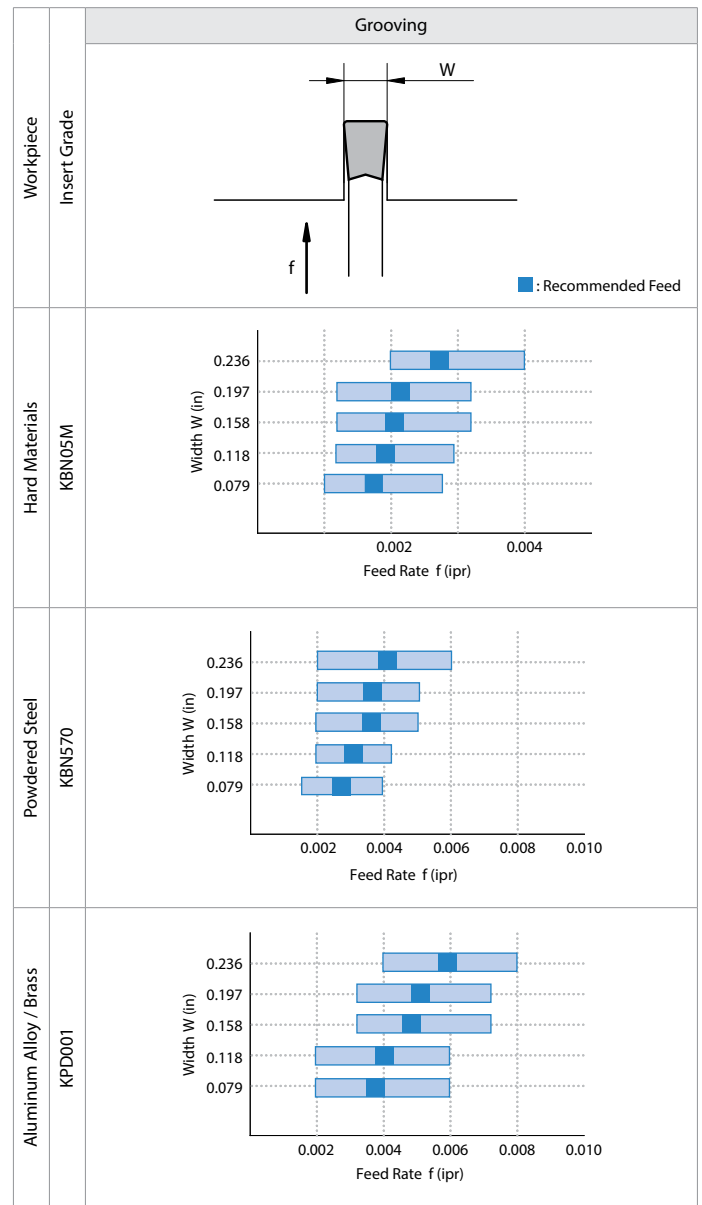

## CM Chipbreaker (Back Turning)

Estimated maximum cutting amount (D.O.C.) for back turning

Part Number	Max. D.O.C. (in)				
	Toolholder Part Number				
	KGD...-2T...	KGD...-3T...	KGD...-4T...	KGD...-5T...	KGD...-6T...
GDM 3020N-150R-CM	0.009	0.008	-	-	-
4020N-200R-CM	-	0.009	0.008	-	-
5020N-250R-CM	-	-	0.012	0.008	-
6020N-300R-CM	-	-	-	0.012	0.010

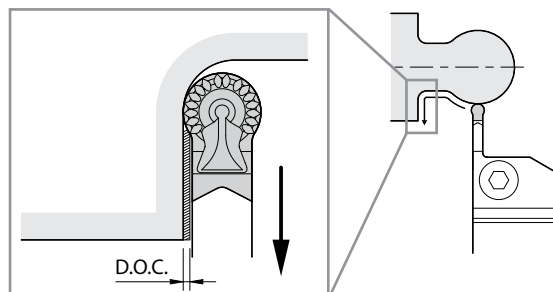

# Recommended Cutting Conditions (Cut-Off) ★ 1st Recommendation ☆ 2nd Recommendation

## PF Chipbreaker

Workpiece	Cutting Conditions (Vc : sfm)				Feed Rate (f : ipr)						Notes
	Recommended Insert Grade				PF Corner-R (rε) = 0.001			PF Corner-R (rε) = 0.006			
	MEGACOAT NANO	MEGACOAT		Carbide	Insert Width (W)			Insert Width (W)			
	PR1535	PR1225	PR1215	GW15	0.051" - 0.059" 1.3mm - 1.5mm	0.079" 2.0mm	0.098" - 0.118" 2.5mm - 3.0mm	0.051" - 0.059" 1.3mm - 1.5mm	0.079" 2.0mm	0.098" - 0.118" 2.5mm - 3.0mm	
Carbon Steel	☆ 230 - 490	★ 230 - 490	☆ 230 - 590	-	0.0004 - 0.0016	0.0008 - 0.0024	0.0008 - 0.0031	0.0004 - 0.0020	0.0012 - 0.0031	0.0016 - 0.0039	
Alloy Steel	☆ 230 - 490	★ 230 - 490	☆ 230 - 590	-							
Stainless Steel	★ 200 - 390	☆ 200 - 390	☆ 200 - 490	-	0.0004 - 0.0012	0.0004 - 0.0016	0.0004 - 0.0020	0.0004 - 0.0016	0.0012 - 0.0028	0.0016 - 0.0031	
Cast Iron	-	-	★ 260 - 660	☆ 160 - 330	0.0004 - 0.0020	0.0008 - 0.0028	0.0012 - 0.0031	0.0004 - 0.0024	0.0012 - 0.0035	0.0016 - 0.0039	

## PQ / PG Chipbreaker

Workpiece	Cutting Conditions (Vc : sfm)				Feed Rate (f : ipr)					Notes
	Recommended Insert Grade				PQ		PG			
	MEGACOAT NANO	MEGACOAT		DLC Coated Carbide	Carbide	Insert Width (W)		Insert Width (W)		
	PR1535	PR1225	PR1215	PDL025	GW15	0.079" 2.0mm	0.098" - 0.118" 2.5mm - 3.0mm	0.079" 2.0mm	0.098" - 0.118" 2.5mm - 3.0mm	
Carbon Steel	☆ 230 - 490	★ 230 - 490	☆ 230 - 590	-	-	0.0012 - 0.0039	0.0016 - 0.0047	0.0004 - 0.0016	0.0004 - 0.0020	
Alloy Steel	☆ 230 - 490	★ 230 - 490	☆ 230 - 590	-	-					
Stainless Steel	★ 200 - 390	☆ 200 - 390	☆ 200 - 490	-	-	0.0008 - 0.0028	0.0008 - 0.0031	0.0004 - 0.0012	0.0004 - 0.0016	
Cast Iron	-	-	★ 260 - 660	-	☆ 160 - 330	0.0016 - 0.0039	0.0016 - 0.0047	0.0004 - 0.0016	0.0004 - 0.0020	
Aluminum Alloy	-	-	-	★ 660 - 1,640	☆ 660 - 1,480	-	-	0.0004 - 0.0020	0.0004 - 0.0024	
Brass	-	-	-	-	★ 330 - 660	-	-	0.0004 - 0.0028	0.0004 - 0.0031	

## PM / PH Chipbreaker

Workpiece	Cutting Conditions (Vc : sfm)			Feed Rate (f : ipr)			Notes
	Recommended Insert Grade			PM	PH		
	MEGACOAT NANO	MEGACOAT		Insert Width (W)	Insert Width (W)		
	PR1535	PR1225	PR1215	0.079" - 0.158" 2.0mm - 4.0mm	0.079" 2.0mm	0.095" - 0.158" 3.0mm - 4.0mm	
Carbon Steel	☆ 260 - 660	★ 260 - 660	☆ 330 - 660	0.0031 - 0.0071	0.0039 - 0.0098	0.0059 - 0.0110	
Alloy Steel	☆ 230 - 590	★ 230 - 590	☆ 260 - 590				
Stainless Steel	★ 200 - 490	☆ 200 - 490	☆ 200 - 490	0.0024 - 0.0047	0.0020 - 0.0047	0.0031 - 0.0059	
Cast Iron	-	-	★ 330 - 660	0.0031 - 0.0071	0.0039 - 0.0098	0.0059 - 0.0110	

## Machining Tips

### Minimum Overhand Length (L2) of the Toolholder

**Advantage 1** Compatible with any machine setups regardless of overhang length specifications

**Advantage 2** Minimum and optimal overhang length helps to control chattering

### Product Lineup with a Maximum Cutting Diameter of 2.008" (51mm)

Note :

When machining large cutting dia. (over 1.417" (36mm)) with KGD%...-3D38 or KGD%...-3D42 or KGD%...-3D51, please follow the instructions below.

· Use 1-Edge inserts

· Maximum workpiece diameter for 2-edge inserts is Ø1.417" (36mm)

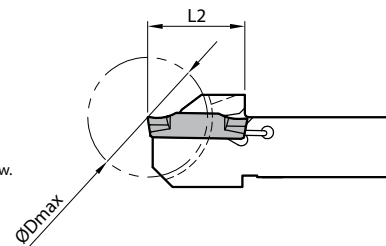

# External Grooving Guide

## ① Turning After Grooving

### 1. Grooving Depths Over 0.020" (0.5mm) : When Roughing (see Fig.1)

Before turning, pull the tool back about 0.004" (1.0mm) after grooving, instead of turning subsequent to grooving.

(Failure to pull the tool back before turning will result in an unbalanced load applied on only one side of the cutting edge.)

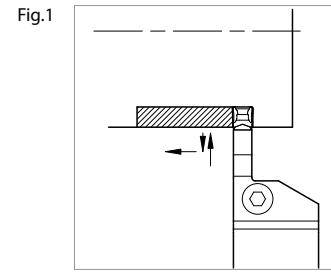

Fig.1  
Before turning, pull the tool back about 0.004" (1.0mm) after grooving.  
(Grooving Depth Over 0.020" (0.5mm) : When Roughing)

### 2. Grooving Depths Under 0.020" (0.5mm) : When Finishing (see Fig.2)

Turning subsequent to grooving is possible because shallow groove depths apply a small load on the cutting edge.

(Dwell-motion is not necessary)

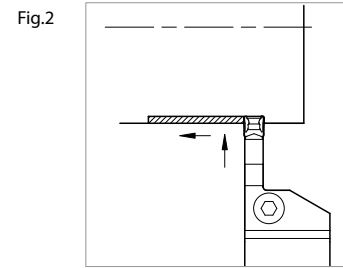

Fig.2  
Turning Subsequent to Grooving.  
(Grooving Depth Under 0.020" (0.5mm) : When Finishing)

## ②

### 1. When widening the groove width, use "Step Turning" as shown in Fig.3

### 2. The widened groove and side walls should be finished last.

(For better chip control, D.O.C. over 0.020" (0.5mm) is recommended.)

Note: If the workpiece is not supported at the center, reduce the feed rate when grooving towards center

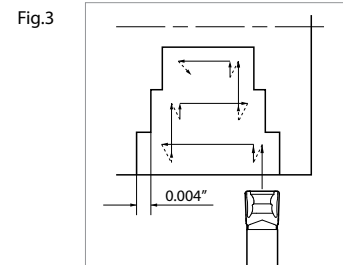

Fig.3

# KGDF Face Grooving

Good Chip Control

MEGACOAT Coating Technology for Long Tool Life and High Efficiency Machining

## 1 Wide Range of Chipbreakers Available for Face Grooving

### Chipbreaker Selection

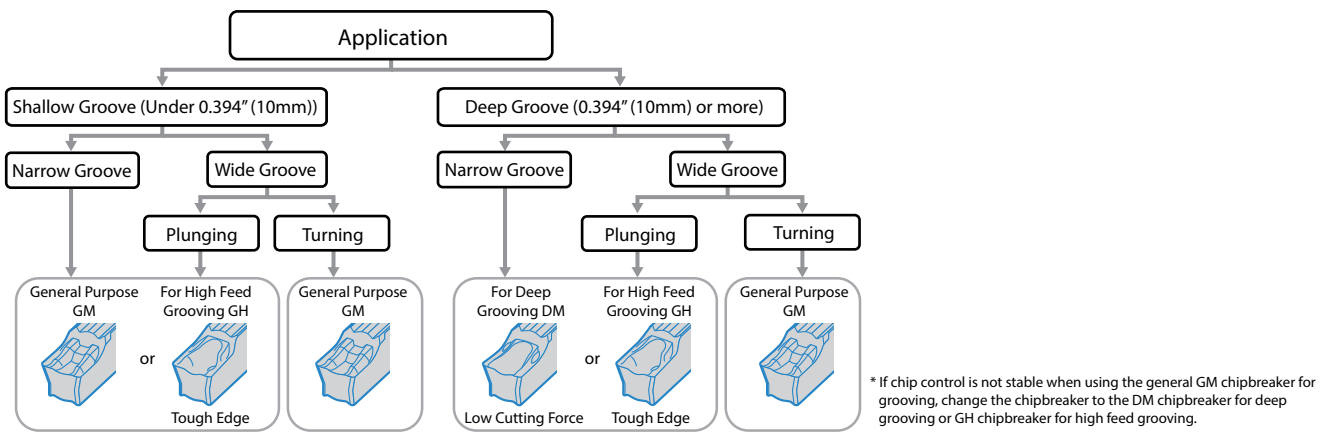

## 2 MEGACOAT Coating Technology for Long Tool Life

### Coating Properties

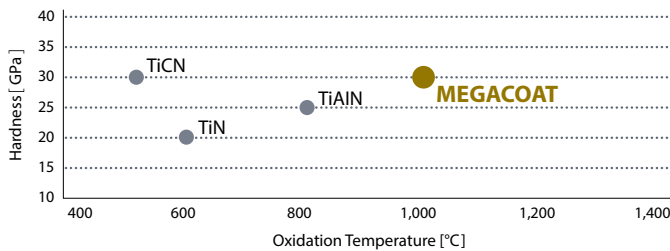

#### PR1225 (MEGACOAT)

1st. Recommendation for Face Grooving

#### PR1215 (MEGACOAT)

Superior Wear Resistance,

1st. Recommendation for Cast Iron Machining



## 3 High Clamping Strength

Prevents abnormal machining surface and / or insert breakage resulting from slip of insert.

Improves repetitive installation accuracy of insert

### New Insert Clamping System "W Grip"

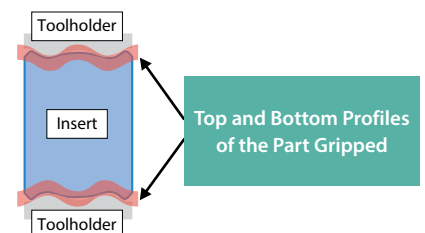

Applicable Inserts

Usage Classification  ● : Light Interruption / 1st Choice ☉ : Light Interruption / 2nd Choice ● : Continuous / 1st Choice ○ : Continuous / 2nd Choice	P	Carbon Steel / Alloy Steel	●	●	☉
	M	Stainless Steel		●	☉
	K	Cast Iron		●	
	N	Non-ferrous Metals			
	S	Titanium Alloy			
	H	Hard Materials (≤40HRC) Hard Materials (≥40HRC)			

	Insert	Part Number	Dimensions (in)						Cermet		MEGACOAT				
			W			rε	M	L	H	TN620	TN90	PR1225	PR1215		
			inch	mm	Tolerance										
Grooving and Turning		GDFM 2020N-020GM	0.079	2.0		0.008	0.059	0.827	0.154		○	○	○	○	
		3020N-030GM	0.118	3.0	±0.0012	0.012	0.083		0.169		○	●	●	●	
		4020N-040GM	0.157	4.0		0.016	0.122					●	●	●	
		5020N-040GM	0.197	5.0		0.016	0.161	0.787				○	●	○	
		5020N-080GM	0.197	5.0		0.031	0.161		0.177			○	○	●	●
		6020N-040GM	0.236	6.0	±0.0016	0.016	0.197					○	●	○	○
		6020N-080GM	0.236	6.0		0.031	0.197				○	○	○	○	
Grooving and Turning (High Feed)		GDFM 4020N-040GH	0.157	4.0	±0.0012	0.016	0.122					○	○	○	
		5020N-040GH	0.197	5.0		0.016	0.161	0.787				○	○	○	
		5020N-080GH	0.197	5.0	±0.0016	0.031	0.161		0.177			○	○	○	
		6020N-040GH	0.236	6.0		0.016	0.197					○	○	○	
		6020N-080GH	0.236	6.0		0.031	0.197					○	○	○	
Deep Grooving and Turning		GDFM 3020N-030DM	0.118	3.0	±0.0012	0.012	0.083		0.169		○	●	●	●	
		4020N-040DM	0.157	4.0		0.016	0.122	0.787			○	●	●	●	
		5020N-040DM	0.197	5.0	±0.0016	0.016	0.161		0.177			○	○	●	●
		6020N-040DM	0.236	6.0		0.016	0.197					○	●	●	●
Deep Grooving and Turning (1-Edge)		GDFMS 3020N-030DM	0.118	3.0	±0.0012	0.012	0.083		0.169		○	●	●	●	
		4020N-040DM	0.157	4.0		0.016	0.122	0.787			○	○	○	○	
		5020N-040DM	0.197	5.0	±0.0016	0.016	0.161		0.177			○	○	○	
		6020N-040DM	0.236	6.0		0.016	0.197					○	●	○	○
Full Radius (R) Grooving		GDFM 3020N-150R-CM	0.118	3.0	±0.0012	0.059	0.083	0.787	0.169	○		●	○	○	
		4020N-200R-CM	0.157	4.0		0.079	0.122	*0.827		○		●	○	○	
		5020N-250R-CM	0.197	5.0	±0.0016	0.098	0.161	*0.827	0.177	○		●	○	○	
		6020N-300R-CM	0.236	6.0		0.118	0.197	*0.866		○		○	●	●	

\* GDFM40/50/60-CM differs from other part numbers in length (L) to avoid interference of the toolholder with workpiece.

● : U.S. Stock ○ : World Express (Shipping: 7-10 Business Days)

Inserts sold in 10 piece boxes

**Insert Identification System**

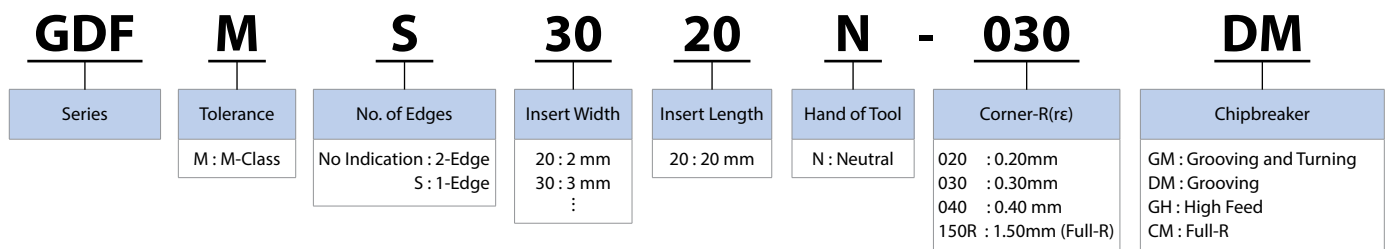



# KGDF | Face Grooving / 0° SwitchBlade (Inch Size)

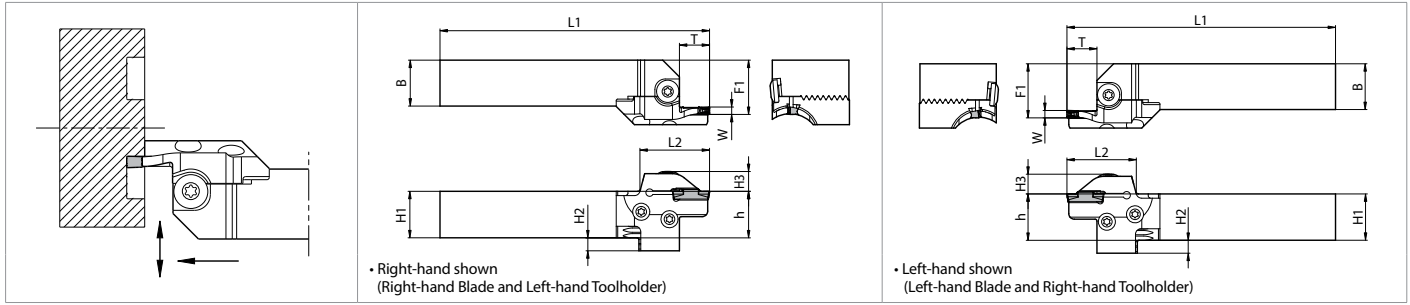

• Right-hand shown  
(Right-hand Blade and Left-hand Toolholder)

• Left-hand shown  
(Left-hand Blade and Right-hand Toolholder)

## Toolholder + Blade Dimensions (0.118" Insert Width)

(Choose **Right-hand** Blade for **Left-hand** Toolholder and **Left-hand** Blade for **Right-hand** Toolholder)

Shank Angle	Insert Width W (in)	Shank Size (in)	Max. Grooving Depth (in)	Face Grooving Dia. ØD (in)		Unit Part Number (Toolholder + Blade)	Toolholder Part Number P13	Stock		Blade Part Number P33	Stock		Dimensions (in)						
				MIN.	MAX.			R	L		R	L	H1=h	H2	H3	B	L1	L2	F1
0°	0.118 (3mm)	0.75	0.512 (13mm)	0.984	1.181	No Unit Part Number →	KGDL12-C	●		KGDFR -25-3A-C	●	0.750	0.510	0.457	0.750	4.650	1.420	0.927	0.512
				-30-3A-C	●														
				-40-3A-C	○														
			0.591 (15mm)	1.969	2.559					KGDFR -50-3B-C	●								
				2.559	3.346					-65-3B-C	●								
				3.346	4.331					-85-3B-C	●								
		0.866 (22mm)	4.331	5.709	-110-3B-C					○									
			1.969	2.559	KGDFR -50-3C-C					○	0.750	0.510	0.457	0.750	5.000	1.770	0.927	0.866	
			2.559	3.346	-65-3C-C					○									
		3.346	4.331	-85-3C-C	○														
		0.984 (25mm)	4.331	5.709	-110-3C-C					●	0.750	0.510	0.457	0.750	5.120	1.890	0.927	0.984	
			0.984	1.181	KGDFR -25-3A-C					●									
	1.181		1.575	-30-3A-C	●														
	1.575		1.969	-40-3A-C	○														
	1.969		2.559	-50-3B-C	●														
	2.559		3.346	-65-3B-C	●														
	0.118 (3mm)	1.00	0.512 (13mm)	0.984	1.181	No Unit Part Number →	KGDL16-C	●		KGDFR -25-3A-C	●	1.000	0.260	0.457	1.000	5.630	1.420	1.177	0.512
				1.181	1.575					-30-3A-C	●								
				1.575	1.969					-40-3A-C	○								
			0.591 (15mm)	1.969	2.559					-50-3B-C	●								
				2.559	3.346					-65-3B-C	●								
				3.346	4.331					-85-3B-C	●								
		0.866 (22mm)	4.331	5.709	-110-3B-C					○									
			1.969	2.559	KGDFR -50-3C-C					○	1.000	0.260	0.457	1.000	5.980	1.770	1.177	0.866	
2.559			3.346	-65-3C-C	○														
3.346		4.331	-85-3C-C	○															
0.984 (25mm)		4.331	5.709	-110-3C-C	●					1.000	0.260	0.457	1.000	6.100	1.890	1.177	0.984		
		0.984	1.181	KGDFL -25-3A-C	●														
	1.181	1.575	-30-3A-C	●															
	1.575	1.969	-40-3A-C	○															
	1.969	2.559	-50-3B-C	○															
	2.559	3.346	-65-3B-C	●															
0.118 (3mm)	0.75	0.512 (13mm)	0.984	1.181	No Unit Part Number →	KGDR12-C	●		KGDFL -25-3A-C	●	0.750	0.510	0.457	0.750	4.650	1.420	0.927	0.512	
			1.181	1.575					-30-3A-C	●									
			1.575	1.969					-40-3A-C	○									
		0.591 (15mm)	1.969	2.559					-50-3B-C	○									
			2.559	3.346					-65-3B-C	●									
			3.346	4.331					-85-3B-C	○									
	0.866 (22mm)	4.331	5.709	-110-3B-C					●										
		1.969	2.559	KGDFL -50-3C-C					●	0.750	0.510	0.457	0.750	5.000	1.770	0.927	0.866		
		2.559	3.346	-65-3C-C					●										
	3.346	4.331	-85-3C-C	●															
	0.984 (25mm)	4.331	5.709	-110-3C-C					●	0.750	0.510	0.457	0.750	5.120	1.890	0.927	0.984		
		0.984	1.181	KGDFL -25-3A-C					●										
1.181		1.575	-30-3A-C	●															
1.575		1.969	-40-3A-C	○															
1.969		2.559	-50-3B-C	○															
2.559		3.346	-65-3B-C	●															
0.118 (3mm)	1.00	0.512 (13mm)	0.984	1.181	No Unit Part Number →	KGDR16-C	●		KGDFL -25-3A-C	●	1.000	0.260	0.457	1.000	5.710	1.500	1.177	0.591	
			1.181	1.575					-30-3A-C	●									
			1.575	1.969					-40-3A-C	○									
		0.591 (15mm)	1.969	2.559					-50-3B-C	○									
			2.559	3.346					-65-3B-C	●									
			3.346	4.331					-85-3B-C	○									
	0.866 (22mm)	4.331	5.709	-110-3B-C					●										
		1.969	2.559	KGDFL -50-3C-C					●	1.000	0.260	0.457	1.000	5.980	1.770	1.177	0.866		
		2.559	3.346	-65-3C-C					●										
	3.346	4.331	-85-3C-C	●															
	0.984 (25mm)	4.331	5.709	-110-3C-C					●	1.000	0.260	0.457	1.000	6.100	1.890	1.177	0.984		
		0.984	1.181	KGDFL -25-3A-C					●										
1.181		1.575	-30-3A-C	●															
1.575		1.969	-40-3A-C	○															
1.969		2.559	-50-3B-C	○															
2.559		3.346	-65-3B-C	●															

Note 1) If the unit part number is not listed (No Unit Part Number), please purchase toolholder and blade separately.

● : U.S. Stock ○ : World Express (Shipping: 7-10 Business Days)

2) Dimension T\* : Shows the maximum grooving depth. If the dimension T is 0.787" (20mm) or more, using a 2-edge insert, the maximum grooving depth is 0.709" (18mm).

3) Insert clamp bolt (BH6x10TR) and Blade fixing bolt (SB-60120TR) come with toolholder. For Spare Parts, see Page 31

Applicable Inserts See Page 22

# KGDF | Face Grooving / 0° SwitchBlade (Inch Size)

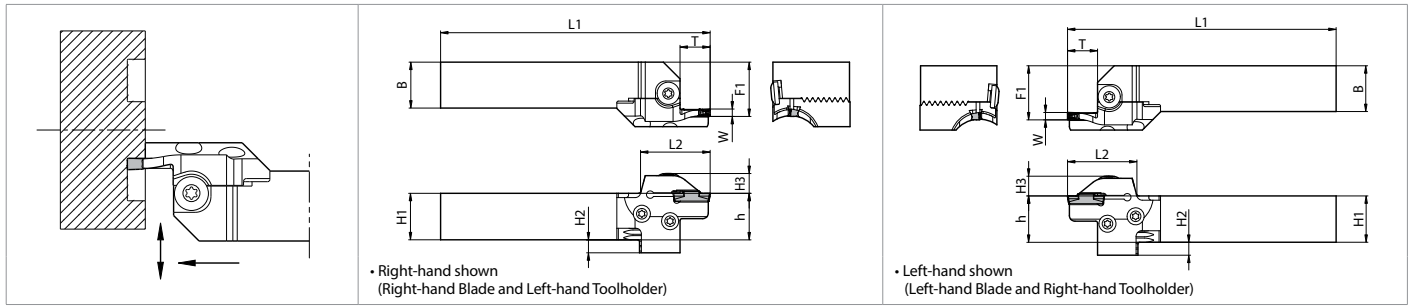

## Toolholder + Blade Dimensions (0.157" Insert Width)

(Choose **Right-hand** Blade for **Left-hand** Toolholder and **Left-hand** Blade for **Right-hand** Toolholder)

Shank Angle	Insert Width W (in)	Shank Size (in)	Max. Grooving Depth (in)	Face Grooving Dia. ØD (in)		Unit Part Number (Toolholder + Blade)	Toolholder Part Number P13	Stock		Blade Part Number P33	Stock		Dimensions (in)							
				MIN.	MAX.			R	L		R	L	H1=h	H2	H3	B	L1	L2	F1	T*
0°	0.157 (4mm)	□ 0.75	0.512 (13mm)	0.984	1.378	No Unit Part Number ➔	KGDL12-C	●		KGDFR -25-4A-C	●	0.750	0.510	0.457	0.750	4.650	1.420	0.927	0.512	
			-35-4B-C	○																
			-50-4B-C	●																
			-70-4B-C	●																
			-100-4B-C	●	0.750					0.510	0.457	0.750	4.720	1.500	0.927	0.591				
			-150-4B-C	○																
		-220-4B-C	○																	
		KGDFR -35-4C-C	○																	
		-50-4C-C	○																	
		-70-4C-C	●	0.750	0.510					0.457	0.750	5.120	1.890	0.927	0.984					
		-100-4C-C	○																	
		-150-4C-C	●																	
	-220-4C-C	○																		
	0.512 (13mm)	0.984	1.378	No Unit Part Number ➔	KGDL16-C	●		KGDFR -25-4A-C	●	1.000	0.260	0.457	1.000	5.630	1.420	1.177	0.512			
	-35-4B-C	○																		
	-50-4B-C	●																		
	-70-4B-C	●																		
	-100-4B-C	●	1.000					0.260	0.457	1.000	5.710	1.500	1.177	0.591						
	-150-4B-C	○																		
	-220-4B-C	○																		
	KGDFR -35-4C-C	○																		
	-50-4C-C	○																		
	-70-4C-C	●	1.000					0.260	0.457	1.000	6.100	1.890	1.177	0.984						
	-100-4C-C	○																		
-150-4C-C	●																			
-220-4C-C	○																			
0°	0.157 (4mm)	□ 0.75	0.512 (13mm)	0.984	1.378	No Unit Part Number ➔	KGDR12-C	●		KGDFL -25-4A-C	●	0.750	0.510	0.457	0.750	4.650	1.420	0.927	0.512	
			-35-4B-C	○																
			-50-4B-C	●																
			-70-4B-C	●																
			-100-4B-C	●	0.750					0.510	0.457	0.750	4.720	1.500	0.927	0.591				
			-150-4B-C	○																
		-220-4B-C	○																	
		KGDFL -35-4C-C	○																	
		-50-4C-C	○																	
		-70-4C-C	○	0.750	0.510					0.457	0.750	5.120	1.890	0.927	0.984					
		-100-4C-C	●																	
		-150-4C-C	○																	
	-220-4C-C	○																		
	0.512 (13mm)	0.984	1.378	No Unit Part Number ➔	KGDR16-C	●		KGDFL -25-4A-C	●	1.000	0.260	0.457	1.000	5.630	1.420	1.177	0.512			
	-35-4B-C	○																		
	-50-4B-C	●																		
	-70-4B-C	●																		
	-100-4B-C	●	1.000					0.260	0.457	1.000	5.710	1.500	1.177	0.591						
	-150-4B-C	○																		
	-220-4B-C	○																		
	KGDFL -35-4C-C	○																		
	-50-4C-C	○																		
	-70-4C-C	○	1.000					0.260	0.457	1.000	6.100	1.890	1.177	0.984						
	-100-4C-C	●																		
-150-4C-C	○																			
-220-4C-C	○																			

Note 1) If the unit part number is not listed (No Unit Part Number), please purchase toolholder and blade separately.

● : U.S. Stock ○ : World Express (Shipping: 7-10 Business Days)

2) Dimension T\* : Shows the maximum grooving depth. If the dimension T is 0.787" (20mm) or more, using a 2-edge insert, the maximum grooving depth is 0.709" (18mm).

3) Insert clamp bolt (BH6x10TR) and Blade fixing bolt (SB-60120TR) come with toolholder. For Spare Parts, see Page 31

Applicable Inserts See Page 22

# KGDF | Face Grooving / 0° SwitchBlade (Inch Size)

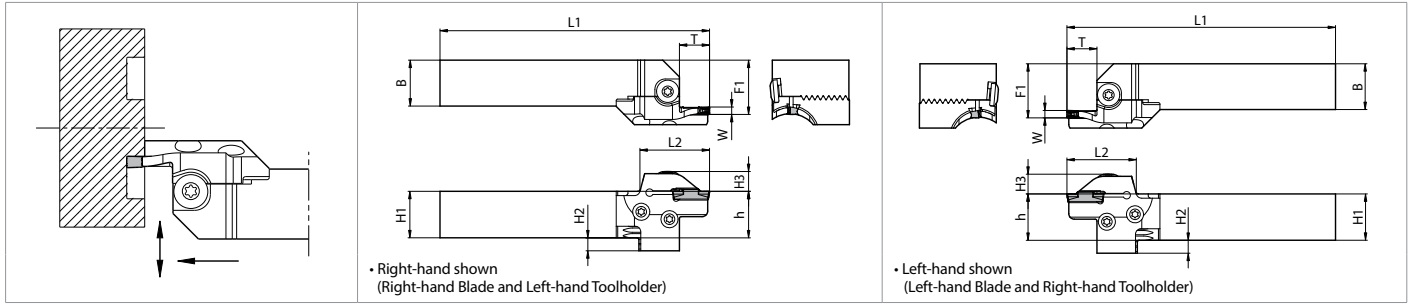

## Toolholder + Blade Dimensions (0.197" Insert Width)

(Choose **Right-hand** Blade for **Left-hand** Toolholder and **Left-hand** Blade for **Right-hand** Toolholder)

Shank Angle	Insert Width W (in)	Shank Size (in)	Max. Grooving Depth (in)	Face Grooving Dia. ØD (in)		Unit Part Number (Toolholder + Blade)	Toolholder Part Number P13	Stock		Blade Part Number P33	Stock		Dimensions (in)														
				MIN.	MAX.			R	L		R	L	H1=h	H2	H3	B	L1	L2	F1	T*							
0°	0.197 (5mm)	0.75	0.591 (15mm)	0.984	1.378	No Unit Part Number ➔	KGDL12-C	●	●	KGDFR -25-5B-C	●	0.750	0.510	0.457	0.750	4.720	1.500	0.927	0.591								
				1.378	1.969					KGDFR -35-5B-C	○																
				1.969	2.953					KGDFR -50-5B-C	●																
				2.953	4.528					KGDFR -75-5B-C	○																
				4.528	7.087					KGDFR -115-5B-C	●																
				7.087	9.252					KGDFR -180-5B-C	●																
		9.252	∞	KGDFR -235-5B-C	●																						
		0.984	1.378	KGDFR -25-5C-C	○					0.750	0.510									0.457	0.750	4.920	1.690	0.927	0.787		
		1.378	1.969	KGDFR -35-5C-C	●																						
		1.969	2.953	KGDFR -50-5C-C	○																						
		2.953	4.528	KGDFR -75-5C-C	○																						
		4.528	7.087	KGDFR -115-5C-C	○																						
	7.087	9.252	KGDFR -180-5C-C	●																							
	9.252	∞	KGDFR -235-5C-C	●																							
	0.984	1.378	KGDFR -25-5B-C	●	1.000	0.260	0.457	1.000	5.700			1.500	1.177	0.591													
	1.378	1.969	KGDFR -35-5B-C	○																							
	1.969	2.953	KGDFR -50-5B-C	●																							
	2.953	4.528	KGDFR -75-5B-C	○																							
	4.528	7.087	KGDFR -115-5B-C	●																							
	7.087	9.252	KGDFR -180-5B-C	●																							
	9.252	∞	KGDFR -235-5B-C	●																							
	0.984	1.378	KGDFR -25-5C-C	○						1.000	0.260				0.457	1.000	5.900	1.690	1.177	0.787							
	1.378	1.969	KGDFR -35-5C-C	●																							
	1.969	2.953	KGDFR -50-5C-C	○																							
2.953	4.528	KGDFR -75-5C-C	○																								
4.528	7.087	KGDFR -115-5C-C	○																								
7.087	9.252	KGDFR -180-5C-C	●																								
9.252	∞	KGDFR -235-5C-C	●																								
0°	0.197 (5mm)	0.75	0.591 (15mm)	0.984	1.378	No Unit Part Number ➔	KGDR12-C	●	●			KGDFL -25-5B-C	●	0.750							0.510	0.457	0.750	4.720	1.500	0.927	0.591
				1.378	1.969							KGDFL -35-5B-C	●														
				1.969	2.953							KGDFL -50-5B-C	○														
				2.953	4.528							KGDFL -75-5B-C	●														
				4.528	7.087							KGDFL -115-5B-C	●														
				7.087	9.252					KGDFL -180-5B-C	○																
		9.252	∞	KGDFL -235-5B-C	●																						
		0.984	1.378	KGDFL -25-5C-C	●					0.750	0.510	0.457	0.750		4.920	1.690	0.927	0.787									
		1.378	1.969	KGDFL -35-5C-C	●																						
		1.969	2.953	KGDFL -50-5C-C	○																						
		2.953	4.528	KGDFL -75-5C-C	●																						
		4.528	7.087	KGDFL -115-5C-C	●																						
	7.087	9.252	KGDFL -180-5C-C	●																							
	9.252	∞	KGDFL -235-5C-C	●																							
	0.984	1.378	KGDFL -25-5B-C	●	1.000	0.260	0.457	1.000	5.700					1.500					1.177	0.591							
	1.378	1.969	KGDFL -35-5B-C	●																							
	1.969	2.953	KGDFL -50-5B-C	○																							
	2.953	4.528	KGDFL -75-5B-C	●																							
	4.528	7.087	KGDFL -115-5B-C	●																							
	7.087	9.252	KGDFL -180-5B-C	○																							
	9.252	∞	KGDFL -235-5B-C	●																							
	0.984	1.378	KGDFL -25-5C-C	●						1.000	0.260	0.457	1.000		5.900	1.690	1.177	0.787									
	1.378	1.969	KGDFL -35-5C-C	●																							
	1.969	2.953	KGDFL -50-5C-C	○																							
2.953	4.528	KGDFL -75-5C-C	●																								
4.528	7.087	KGDFL -115-5C-C	●																								
7.087	9.252	KGDFL -180-5C-C	●																								
9.252	∞	KGDFL -235-5C-C	●																								

Note 1) If the unit part number is not listed (No Unit Part Number), please purchase toolholder and blade separately.

● : U.S. Stock ○ : World Express (Shipping: 7-10 Business Days)

2) Dimension T\* : Shows the maximum grooving depth. If the dimension T is 0.787" (20mm) or more, using a 2-edge insert, the maximum grooving depth is 0.709" (18mm).

3) Insert clamp bolt (BH6x10TR) and Blade fixing bolt (SB-60120TR) come with toolholder. For Spare Parts, see [Page 31](#)

Applicable Inserts See [Page 22](#)

# KGDF | Face Grooving / 0° SwitchBlade (Inch Size)

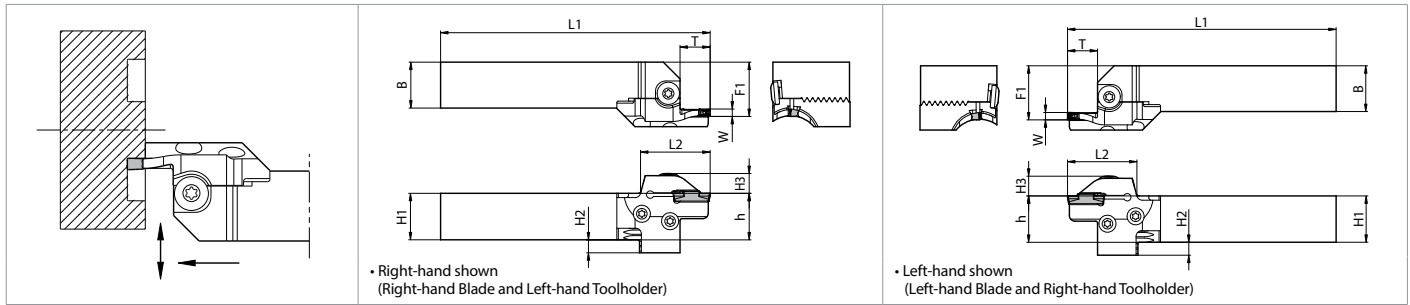

## Toolholder + Blade Dimensions (0.236" Insert Width)

(Choose **Right-hand** Blade for **Left-hand** Toolholder and **Left-hand** Blade for **Right-hand** Toolholder)

Shank Angle	Insert Width W (in)	Shank Size (in)	Max. Grooving Depth (in)	Face Grooving Dia. ØD (in)		Unit Part Number (Toolholder + Blade)	Toolholder Part Number P13	Stock		Blade Part Number P33	Stock		Dimensions (in)																		
				MIN.	MAX.			R	L		R	L	H1=h	H2	H3	B	L1	L2	F1	T*											
0°	0.236 (6mm)	0.75	0.591 (15mm)	0.984	1.378	No Unit Part Number ➔	KGDL12-C	●	●	KGDFR -25-6B-C	●	0.750	0.510	0.457	0.750	4.720	1.500	0.927	0.591												
				1.378	1.969					KGDFR -35-6B-C	●																				
				1.969	2.953					KGDFR -50-6B-C	○																				
				2.953	4.528					KGDFR -75-6B-C	●																				
				4.528	7.087					KGDFR -115-6B-C	●																				
				7.087	9.252					KGDFR -180-6B-C	●																				
		9.252	∞	KGDFR -235-6B-C	○																										
		1.00	0.787 (20mm)	0.984	1.378					No Unit Part Number ➔	KGDL16-C									●	●	KGDFR -25-6B-C	●	1.000	0.260	0.457	1.000	5.920	1.690	1.177	0.787
				1.378	1.969																	KGDFR -35-6C-C	●								
				1.969	2.953																	KGDFR -50-6C-C	●								
				2.953	4.528																	KGDFR -75-6C-C	○								
				4.528	7.087																	KGDFR -115-6C-C	●								
7.087	9.252			KGDFR -180-6C-C	●																										
9.252	∞	KGDFR -235-6C-C	○																												
1.00	0.984 (25mm)	0.984	1.378	No Unit Part Number ➔	KGDL16-C	●	●	KGDFR -25-6B-C	●			1.000	0.260	0.457	1.000	6.100	1.890	1.177	0.984												
		1.378	1.969					KGDFR -35-6C-C	●																						
		1.969	2.953					KGDFR -50-6C-C	●																						
		2.953	4.528					KGDFR -75-6C-C	○																						
		4.528	7.087					KGDFR -115-6C-C	●																						
		7.087	9.252					KGDFR -180-6C-C	●																						
9.252	∞	KGDFR -235-6C-C	○																												
0°	0.236 (6mm)	0.75	0.591 (15mm)					0.984	1.378	No Unit Part Number ➔	KGDR12-C									●	●	KGDFL -25-6B-C	●	0.750	0.510	0.457	0.750	4.720	1.500	0.927	0.591
								1.378	1.969													KGDFL -35-6B-C	●								
								1.969	2.953													KGDFL -50-6B-C	●								
								2.953	4.528													KGDFL -75-6B-C	●								
								4.528	7.087													KGDFL -115-6B-C	●								
				7.087	9.252	KGDFL -180-6B-C	●																								
		9.252	∞	KGDFL -235-6B-C	●																										
		1.00	0.787 (20mm)	0.984	1.378	No Unit Part Number ➔	KGDR16-C	●	●			KGDFL -25-6B-C	●	1.000	0.260	0.457	1.000	5.900	1.690			1.177	0.787								
				1.378	1.969							KGDFL -35-6B-C	●																		
				1.969	2.953							KGDFL -50-6B-C	●																		
				2.953	4.528							KGDFL -75-6B-C	●																		
				4.528	7.087							KGDFL -115-6B-C	●																		
7.087	9.252			KGDFL -180-6B-C	●																										
9.252	∞	KGDFL -235-6B-C	●																												
1.00	0.984 (25mm)	0.984	1.378	No Unit Part Number ➔	KGDR16-C					●	●	KGDFL -25-6B-C	●							1.000	0.260			0.457	1.000	6.100	1.890	1.177	0.984		
		1.378	1.969									KGDFL -35-6C-C	●																		
		1.969	2.953									KGDFL -50-6C-C	●																		
		2.953	4.528									KGDFL -75-6C-C	●																		
		4.528	7.087									KGDFL -115-6C-C	●																		
		7.087	9.252			KGDFL -180-6C-C	●																								
9.252	∞	KGDFL -235-6C-C	●																												

Note 1) If the unit part number is not listed (No Unit Part Number), please purchase toolholder and blade separately. ● : U.S. Stock ○ : World Express (Shipping: 7-10 Business Days)

2) Dimension T\* : Shows the maximum grooving depth. If the dimension T is 0.787" (20mm) or more, using a 2-edge insert, the maximum grooving depth is 0.709" (18mm).

3) Insert clamp bolt (BH6x10TR) and Blade fixing bolt (SB-60120TR) come with toolholder. For Spare Parts, see Page 31

Applicable Inserts See Page 22

# KGDF | Face Grooving / 0° SwitchBlade (Metric Size)

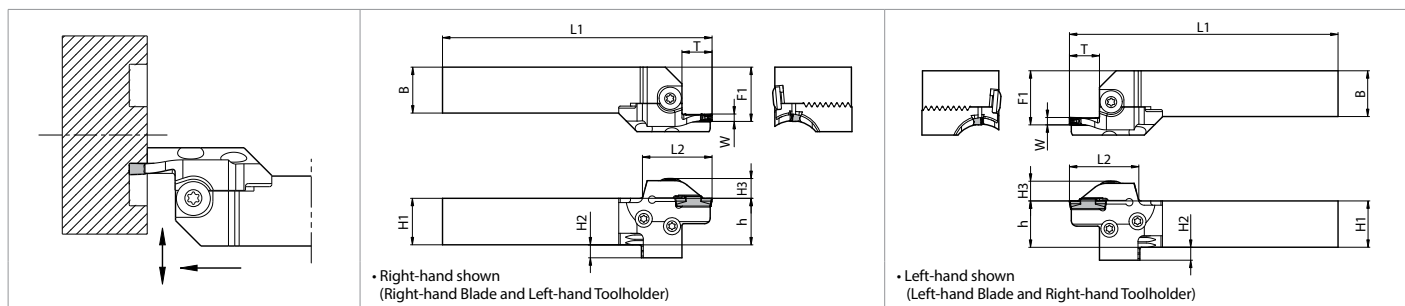

## Toolholder + Blade Dimensions (2mm Insert Width)

(Choose **Right-hand** Blade for **Left-hand** Toolholder and **Left-hand** Blade for **Right-hand** Toolholder)

Shank Angle	Insert Width W (mm)	Shank Size (mm)	Max. Grooving Depth (mm)	Face Grooving Dia. ØD (mm)		Unit Part Number (Toolholder + Blade)	Stock		Toolholder Part Number P13	Stock		Blade Part Number P33	Stock		Dimensions (mm)							
				MIN.	MAX.		R	L		R	L		R	L	H1=h	H2	H3	B	L1	L2	F1	T*
0°	2	□20	6	25	30	KGDFR 2020X25-2AS	○		KGDL2020-C	○		KGDFR -25-2A-C	○		20	12	11.6	20	115	33	24.5	6
				30	35		○			○			○									
				35	45		○			○			●									
				45	60		○			○			○									
				60	80		○			○			○									
				80	100		○			○			○									
		15	35	45	No Unit Part Number ➔								○		20	12	11.6	20	120	38	24.5	15
		□25	6	25	30	KGDFR 2525X25-2AS	○		KGDL2525-C	○		KGDFR -25-2A-C	○		25	7	11.6	25	140	33	29.5	6
				30	35		○			○			○									
				35	45		○			○			●									
				45	60		○			○			○									
				60	80		○			○			○									
	80			100	○			○			○											
	15	35	45	No Unit Part Number ➔								○		25	7	11.6	25	145	38	29.5	15	
	□32	6	25	30	No Unit Part Number ➔				KGDL3232-C	○		KGDFR -25-2A-C	○		32	7	11.6	32	160	33	36.5	6
			30	35			○			○												
			35	45			○			●												
			45	60			○			○												
			60	80			○			○												
			80	100			○			○												
	15	35	45	No Unit Part Number ➔								○		32	7	11.6	32	165	38	36.5	15	

Note 1) If the unit part number is not listed (No Unit Part Number), please purchase toolholder and blade separately. ● : U.S. Stock ○ : World Express (Shipping: 7-10 Business Days)

2) Dimension T\* : Shows the maximum grooving depth. If the dimension T is (20mm) or more, using a 2-edge insert, the maximum grooving depth is (18mm).

3) Insert clamp bolt (BH6x10TR) and Blade fixing bolt (SB-60120TR) come with toolholder. For Spare Parts, see Page 31

Applicable Inserts See Page 22





# KGDF | Face Grooving / 0° SwitchBlade (Metric Size)

Toolholder + Blade Dimensions (5mm Insert Width)

(Choose **Right-hand** Blade for **Left-hand** Toolholder and **Left-hand** Blade for **Right-hand** Toolholder)

Shank Angle	Insert Width W (mm)	Shank Size (mm)	Max. Grooving Depth (mm)	Face Grooving Dia. ØD (mm)		Unit Part Number (Toolholder + Blade)	Stock		Toolholder Part Number P13	Stock		Blade Part Number P33	Stock		Dimensions (mm) Diagram on Page P27										
				MIN.	MAX.		R	L		R	L		R	L	H1=h	H2	H3	B	L1	L2	F1	T*			
0°	5	□20	15	25	35	KGDF% 2020X25-5BS	○	○	KGDF% 2020-C	○	○	KGDF% -25-5B-C	●	●	20	12	11.6	20	120	38	24.5	15			
				35	50	2020X35-5BS	○	○		-35-5B-C	○	●													
				50	75	2020X50-5BS	○	○		-50-5B-C	●	○													
				75	115	2020X75-5BS	○	○		-75-5B-C	○	●													
				115	180	2020X115-5BS	○	○		-115-5B-C	●	●													
				180	235	2020X180-5BS	○	○		-180-5B-C	●	○													
				235	∞	2020X235-5BS	○	○		-235-5B-C	●	●													
			20	25	35	KGDF% 2020X25-5CS	○	○		KGDF% 2020-C	○	○	KGDF% -25-5C-C	○	●	20	12	11.6	20	125	43	24.5	20		
				35	50	2020X35-5CS	○	○			-35-5C-C	●	●												
				50	75	2020X50-5CS	○	○			-50-5C-C	○	●												
				75	115	2020X75-5CS	○	○			-75-5C-C	○	●												
				115	180	2020X115-5CS	○	○			-115-5C-C	○	●												
				180	235	2020X180-5CS	○	○			-180-5C-C	●	●												
				235	∞	2020X235-5CS	○	○			-235-5C-C	●	●												
			32	75	115	No Unit Part Number →				KGDF% 2020-C	○	○	KGDF% -75-5D-C	○	●	20	12	11.6	20	137	55	24.5	32		
				115	180						-115-5D-C	○	○												
				180	235						-180-5D-C	●	●												
				235	∞						-235-5D-C	○	●												
			□25	15	25	35	KGDF% 2525X25-5BS	○		○	KGDF% 2525-C	○	○	KGDF% -25-5B-C	●	●	25	7	11.6	25	145	38	29.5	15	
					35	50	2525X35-5BS	○		○		-35-5B-C	○	●											
					50	75	2525X50-5BS	○		○		-50-5B-C	●	○											
					75	115	2525X75-5BS	○		○		-75-5B-C	○	●											
					115	180	2525X115-5BS	○		○		-115-5B-C	●	●											
		180			235	2525X180-5BS	○	○	-180-5B-C	●		○													
		235			∞	2525X235-5BS	○	○	-235-5B-C	●		●													
		20		25	35	KGDF% 2525X25-5CS	○	○	KGDF% 2525-C	○		○	KGDF% -25-5C-C	○	●	25	7	11.6	25	150	43	29.5	20		
				35	50	2525X35-5CS	○	○		-35-5C-C		○	●												
				50	75	2525X50-5CS	○	○		-50-5C-C		○	●												
				75	115	No Unit Part Number →				-75-5C-C		○	●												
				115	180					-115-5C-C		○	●												
		32		180	235	No Unit Part Number →				-180-5C-C		●	●												
				235	∞					-235-5C-C		●	●												
				75	115	KGDF% 2525X75-5DS	○	○	KGDF% 2525-C	○		○	KGDF% -75-5D-C	○	●	25	7	11.6	25	155	48	29.5	25		
				115	180	2525X115-5DS	○	○		-115-5D-C		○	○												
				180	235	2525X180-5DS	○	○		-180-5D-C		●	●												
				235	∞	2525X235-5DS	○	○		-235-5D-C		○	○												
		□32		15	25	35	No Unit Part Number →					KGDF% 3232-C	○	○	KGDF% -25-5B-C	●	●	32	-	11.6	32	165	38	36.5	15
					35	50							-35-5B-C	○	●										
					50	75							-50-5B-C	●	○										
			75		115					-75-5B-C	○		●												
			115		180					-115-5B-C	●		●												
			180		235					-180-5B-C	●		○												
			235		∞					-235-5B-C	●		●												
			20	25	35	No Unit Part Number →				KGDF% 3232-C	○		○	KGDF% -25-5C-C	○	●	32	-	11.6	32	170	43	36.5	20	
35	50							-35-5C-C	●		●														
50	75							-50-5C-C	○		●														
75	115							-75-5C-C	○		●														
115	180							-115-5C-C	○		●														
32	180		235					-180-5C-C	●	●															
	235		∞					-235-5C-C	●	●															
	75		115	No Unit Part Number →				KGDF% 3232-C	○	○	KGDF% -75-5D-C		○	●	32	-	11.6	32	182	55	36.5	32			
	115		180						-115-5D-C	○	○														
	180		235						-180-5D-C	●	●														
	235		∞						-235-5D-C	○	●														

Note 1) If the unit part number is not listed (No Unit Part Number), please purchase toolholder and blade separately. ● : U.S. Stock ○ : World Express (Shipping: 7-10 Business Days)  
 2) Dimension T\* : Shows the maximum grooving depth. If the dimension T is (20mm) or more, using a 2-edge insert, the maximum grooving depth is (18mm). Applicable Inserts See Page 22  
 3) Insert clamp bolt (BH6x10TR) and Blade fixing bolt (SB-60120TR) come with toolholder. For Spare Parts, see Page 31

# KGDF | Face Grooving / 0° SwitchBlade (Metric Size)

Toolholder + Blade Dimensions (6mm Insert Width)

(Choose **Right-hand** Blade for **Left-hand** Toolholder and **Left-hand** Blade for **Right-hand** Toolholder)

Shank Angle	Insert Width W (mm)	Shank Size (mm)	Max. Grooving Depth (mm)	Face Grooving Dia. ØD (mm)		Unit Part Number (Toolholder + Blade)	Stock		Toolholder Part Number P13	Stock		Blade Part Number P33	Stock		Dimensions (mm) Diagram on Page P27											
				MIN.	MAX.		R	L		R	L		R	L	H1=h	H2	H3	B	L1	L2	F1	T*				
0°	6	□20	15	25	35	KGDF <sup>R/L</sup> 2020X25-6BS	○	○	KGDF <sup>R/L</sup> 2020-C	○	○	KGDF <sup>R/L</sup> -25-6B-C	●	●	20	12	11.6	20	120	38	24.5	15				
				35	50	2020X35-6BS	○	○		-35-6B-C	●	●														
				50	75	2020X50-6BS	○	○		-50-6B-C	○	●														
				75	115	2020X75-6BS	○	○		-75-6B-C	●	●														
				115	180	2020X115-6BS	○	○		-115-6B-C	●	●														
				180	235	2020X180-6BS	○	○		-180-6B-C	●	●														
			235	∞	2020X235-6BS	○	○	-235-6B-C		○	●															
			20	25	35	KGDF <sup>R/L</sup> 2020X25-6CS	○	○		KGDF <sup>R/L</sup> 2020-C	○	○	KGDF <sup>R/L</sup> -25-6C-C	●	●	20	12	11.6	20	125	43	24.5	20			
				35	50	2020X35-6CS	○	○			-35-6C-C	●	●													
				50	75	2020X50-6CS	○	○			-50-6C-C	●	●													
				75	115	2020X75-6CS	○	○			-75-6C-C	○	●													
				115	180	2020X115-6CS	○	○			-115-6C-C	●	●													
		180		235	2020X180-6CS	○	○	-180-6C-C	●		●															
		235	∞	2020X235-6CS	○	○	-235-6C-C	●	●																	
		32	75	115	No Unit Part Number →				KGDF <sup>R/L</sup> 2020-C		○	○	KGDF <sup>R/L</sup> -75-6D-C	●	●	20	12	11.6	20	137	55	24.5	32			
			115	180	No Unit Part Number →						-115-6D-C	●	●													
			180	235	No Unit Part Number →						-180-6D-C	●	●													
			235	∞	No Unit Part Number →						-235-6D-C	●	●													
			235	∞	No Unit Part Number →						-235-6D-C	●	●													
		0°	6	□25	15	25	35	KGDF <sup>R/L</sup> 2525X25-6BS		○	○	KGDF <sup>R/L</sup> 2525-C	○	○	KGDF <sup>R/L</sup> -25-6B-C	●	●	25	7	11.6	25	145	38	29.5	15	
						35	50	2525X35-6BS		○	○		-35-6B-C	●	●											
						50	75	2525X50-6BS		○	○		-50-6B-C	○	●											
						75	115	2525X75-6BS		○	○		-75-6B-C	●	●											
						115	180	2525X115-6BS		○	○		-115-6B-C	●	●											
180	235					2525X180-6BS	○	○		-180-6B-C	●		●													
235	∞				2525X235-6BS	○	○	-235-6B-C		○	●															
20	25				35	KGDF <sup>R/L</sup> 2525X25-6CS	○	○	KGDF <sup>R/L</sup> 2525-C	○	○		KGDF <sup>R/L</sup> -25-6C-C	●	●	25	7	11.6	25	150	43	29.5	20			
	35				50	2525X35-6CS	○	○		-35-6C-C	●		●													
	50				75	2525X50-6CS	○	○		-50-6C-C	●		●													
	75				115	No Unit Part Number →				-75-6C-C	○		●													
	115				180	No Unit Part Number →				-115-6C-C	●		●													
	180			235	No Unit Part Number →					-180-6C-C	●	●														
235	∞			No Unit Part Number →				-235-6C-C		●	●															
32	75			115	KGDF <sup>R/L</sup> 2525X75-6DS	○	○	KGDF <sup>R/L</sup> 2525-C		○	○	KGDF <sup>R/L</sup> -75-6D-C	●	●	25	7	11.6	25	162	55	29.5	32				
	115			180	2525X115-6DS	○	○			-115-6D-C	●	●														
	180			235	2525X180-6DS	○	○			-180-6D-C	●	●														
	235			∞	2525X235-6DS	○	○			-235-6D-C	●	●														
	235			∞	No Unit Part Number →					-235-6D-C	●	●														
0°	6			□32	15	25	35		No Unit Part Number →				KGDF <sup>R/L</sup> 3232-C	○	○	KGDF <sup>R/L</sup> -25-6B-C	●	●	32	-	11.6	32	165	38	36.5	15
						35	50		No Unit Part Number →					-35-6B-C	●	●										
						50	75		No Unit Part Number →					-50-6B-C	○	●										
						75	115		No Unit Part Number →					-75-6B-C	●	●										
						115	180		No Unit Part Number →					-115-6B-C	●	●										
		180	235			No Unit Part Number →				-180-6B-C	●	●														
		235	∞		No Unit Part Number →				-235-6B-C	○	●															
		20	25		35	No Unit Part Number →				KGDF <sup>R/L</sup> 3232-C	○	○		KGDF <sup>R/L</sup> -25-6C-C	●	●	32	-	11.6	32	170	43	36.5	20		
			35		50	No Unit Part Number →					-35-6C-C	●		●												
			50		75	No Unit Part Number →					-50-6C-C	●		●												
			75		115	No Unit Part Number →					-75-6C-C	○		●												
			115		180	No Unit Part Number →					-115-6C-C	●		●												
			180	235	No Unit Part Number →				-180-6C-C		●	●														
		235	∞	No Unit Part Number →				-235-6C-C	●		●															
		32	75	115	No Unit Part Number →				KGDF <sup>R/L</sup> 3232-C		○	○	KGDF <sup>R/L</sup> -75-6D-C	●	●	32	-	11.6	32	182	55	36.5	32			
			115	180	No Unit Part Number →						-115-6D-C	●	●													
			180	235	No Unit Part Number →						-180-6D-C	●	●													
			235	∞	No Unit Part Number →						-235-6D-C	●	●													
			235	∞	No Unit Part Number →						-235-6D-C	●	●													

Note 1) If the unit part number is not listed (No Unit Part Number), please purchase toolholder and blade separately.



● : U.S. Stock ○ : World Express (Shipping: 7-10 Business Days)

2) Dimension T\* : Shows the maximum grooving depth. If the dimension T is (20mm) or more, using a 2-edge insert, the maximum grooving depth is (18mm).

3) Insert clamp bolt (BH6x10TR) and Blade fixing bolt (SB-60120TR) come with toolholder. For Spare Parts, see Page 31

Applicable Inserts See Page 22

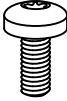
## Spare Parts (Common with SwitchBlade Holders)

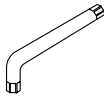
Unit Part Number	Spare Parts		
	Clamp Screw (for Insert Clamp)	Clamp Screw (for Blade)	Wrench
			
KGDF <sup>®</sup> /L...S	BH6X10TR	SB-60120TR	LTW-25

\*The spare parts above are included with the toolholder and unit.

## KGDF Toolholder Assembly Identification (Face Grooving - SwitchBlade)

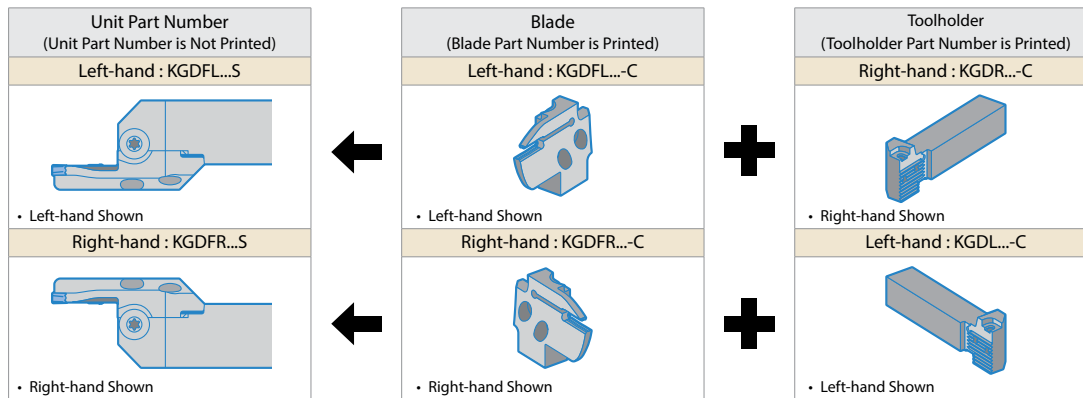

- **Right-hand** Blade for **Left-hand** Toolholder, **Left-hand** Blade for **Right-hand** Toolholder.
- The Unit Part Number is not printed on the product. It is printed on the box label.
- Combination of the toolholder and blade (both sold separately) can make up the corresponding assembly.
- The insert clamping screw (BH6X10TR), blade fixing screw (SB-60120TR) and wrench (LTW-25) which are included with the toolholder can be used.

## Face Grooving Toolholder Assembly Identification System (Face Grooving - SwitchBlade)

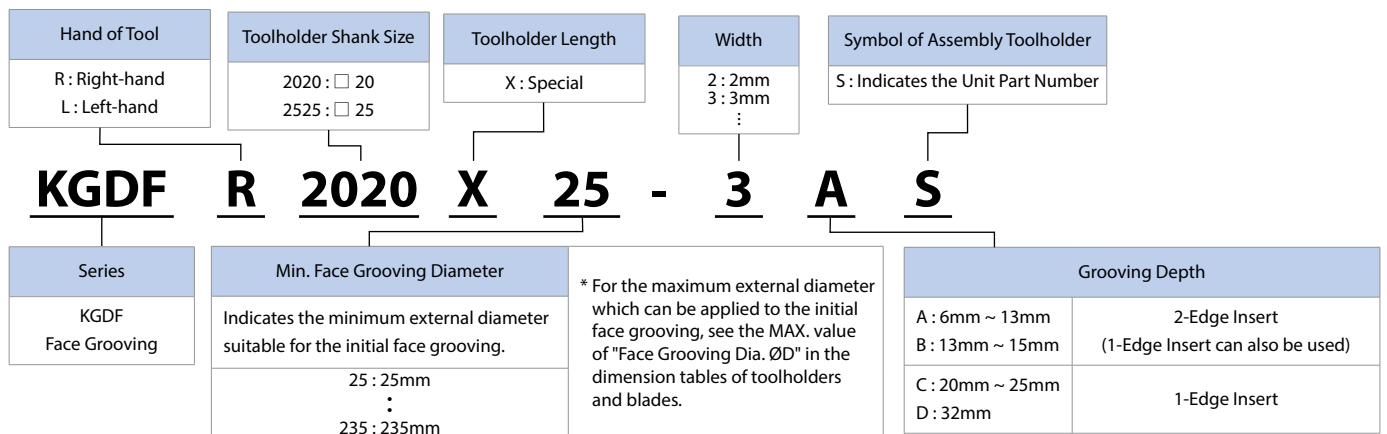

## Face Grooving Dia. (ØD)

Face grooving diameter (ØD) is the suitable value for the initial grooving on the unprocessed workpiece (See Fig.1).

Then, you can widen it up to the center towards the inside (excluding the models listed in the below table) and towards the outside according to machine limits.

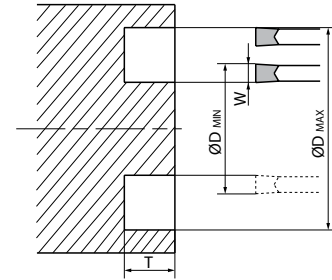

Fig.1

## Limit of Turning Toward Center

Turning towards the Center causes the toolholder to interfere with the groove wall depending on the initial cut's diameter.

	ØD (mm)		25	26	27	28 and over
	Part Number		Ød(mm)			
KGDF <sup>R/L</sup>	2020X25-3AS	4	2	0	0 (No remaining Boss)	
	2525X25-3AS					
KGDF <sup>R/L</sup>	2020X25-4AS	6	3	0		
	2525X25-4AS					
KGDF <sup>R/L</sup>	2020X25-5AS	7	4	1		
	2525X25-5AS					
KGDF <sup>R/L</sup>	2020X25-6AS	9	4	1		
	2525X25-6AS					

e.g.) If the groove of external diameter Ø0.984" (25mm) is created using KGDFR2020X25-3AS and turning is made toward the inside, a Ø0.158" (4mm) portion will be left in middle due to interference of toolholder.

## Face Grooving Blade Assembly Identification System

Hand of Tool	Width	Blade Symbol
R : Right-hand L : Left-hand	2 : 2mm    5 : 5mm 3 : 3mm    6 : 6mm 4 : 4mm	C : Applicable to toolholder with suffix "-C"

  

<b>KGDF</b>	<b>R</b>	<b>- 25</b>	<b>- 3</b>	<b>A</b>	<b>- C</b>
Series	Min. Face Grooving Diameter		Grooving Depth		
KGDF Face Grooving	Indicates the minimum external diameter suitable for the initial face grooving. 25 : 25mm ⋮ 235 : 235mm		A : 13mm B : 15mm C : 20mm ~ 25mm D : 32mm	2-Edge Insert (1-Edge Insert can also be used)  1-Edge Insert	

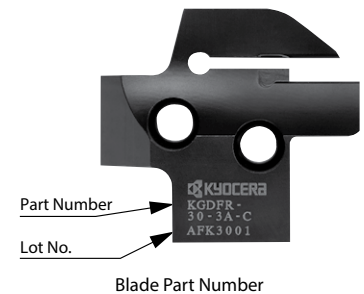

# Face Grooving Blades

## Blade Dimensions

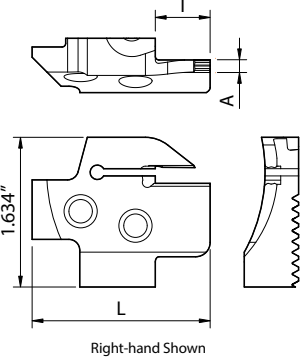
Shape	Blade Part Number	Stock		Dimensions (in)			Face Grooving Dia. ØD (in)		Insert Width (in) W	Applicable Inserts P22	Toolholder Part Number P13	
		R	L	L	T	A	MIN.	MAX.				
 <p>Right-hand Shown</p>	KGDFR	-25-2A-C	○	1.746	0.236	0.059	0.984	1.181	0.079 (2mm)	GDFM 2020N-020GM		
		-30-2A-C	○				1.181	1.378				
		-35-2A-C	●				1.378	1.772				
		-45-2A-C	○				1.772	2.362				
		-60-2A-C	○				2.362	3.150				
		-80-2A-C	○				3.150	3.937				
	-100-2A-C	○	3.937	5.118								
	-35-2B-C	○	1.943	0.591	1.378	1.772	0.079	0.118 (3mm)	GDFM 3020N-030GM GDFM 3020N-030DM GDFMS 3020N-030DM GDFM 3020N-150R-CM			
	KGDF%	-25-3A-C	●	●	1.864	0.512				0.984		1.181
		-30-3A-C	●	●						1.181		1.575
		-40-3A-C	○	○						1.575		1.969
	-50-3B-C	●	○	1.943	0.591	1.969				2.559		
	-65-3B-C	●	○			2.559				3.346		
	-85-3B-C	●	○			3.346				4.331		
	-110-3B-C	○	●	2.219	0.866	4.331				5.709		
	-50-3C-C	○	●			1.969				2.559		
	-65-3C-C	○	●			2.559				3.346		
	-85-3C-C	○	●	2.337	0.984	3.346				4.331		
	-110-3C-C	○	●			4.331				5.709		
	KGDF%	-25-4A-C	●			●	1.943	0.591	0.118	0.157 (4mm)		GDFM 4020N-040GM GDFM 4020N-040GH GDFM 4020N-040DM GDFMS 4020N-040DM GDFM 4020N-200R-CM
		-35-4B-C	○	○	0.984	1.378						
		-50-4B-C	●	●	1.378	1.969						
		-70-4B-C	●	●	1.969	2.756						
		-100-4B-C	●	●	2.756	3.937						
		-150-4B-C	○	○	3.937	5.906						
		-220-4B-C	○	○	5.906	8.661						
		-35-4C-C	○	○	8.661	∞						
		-50-4C-C	○	●	1.378	1.969						
		-70-4C-C	○	●	1.969	2.756						
		-100-4C-C	○	○	2.756	3.937						
		-150-4C-C	○	○	3.937	5.906						
	-220-4C-C	○	○	5.906	8.661							
	KGDF%	-25-5B-C	●	●	1.943	0.591	0.157	0.197 (5mm)	GDFM 5020N-040GM GDFM 5020N-080GM GDFM 5020N-040GH GDFM 5020N-080GH GDFM 5020N-040DM GDFMS 5020N-040DM GDFM 5020N-250R-CM			
		-35-5B-C	○	●						0.984		1.378
		-50-5B-C	○	○						1.378		1.969
		-75-5B-C	○	●						1.969		2.953
		-115-5B-C	●	●						2.953		4.528
		-180-5B-C	●	○						4.528		7.087
		-235-5B-C	●	●						7.087		9.252
		-25-5C-C	○	○						9.252		∞
		-35-5C-C	●	●						0.984		1.378
		-50-5C-C	○	●						1.378		1.969
		-75-5C-C	○	●						1.969		2.953
		-115-5C-C	○	●						2.953		4.528
		-180-5C-C	○	●						4.528		7.087
-235-5C-C		●	●	7.087						9.252		
KGDF%		-25-6B-C	○	○						2.140	0.787	0.197
	-35-6B-C	○	○	0.984	1.378							
	-50-6B-C	○	○	1.378	1.969							
	-75-6B-C	○	○	1.969	2.953							
	-115-6B-C	○	○	2.953	4.528							
	-180-6B-C	○	○	4.528	7.087							
	-235-6B-C	○	○	7.087	9.252							
	-25-6C-C	○	○	9.252	∞							
	-35-6C-C	○	○	0.984	1.378							
KGDF%	-50-6C-C	○	○	2.337	0.984	0.197	0.236 (6mm)	GDFM 6020N-040GM GDFM 6020N-080GM GDFM 6020N-040GH GDFM 6020N-080GH GDFM 6020N-040DM GDFMS 6020N-040DM GDFM 6020N-300R-CM				
	-75-6C-C	○	○						1.378	1.969		
	-115-6C-C	○	○						1.969	2.953		
	-180-6C-C	○	○						2.953	4.528		
	-235-6C-C	○	○						4.528	7.087		
	-75-6D-C	○	○						7.087	9.252		
	-115-6D-C	○	○						9.252	∞		
	-180-6D-C	○	○						2.953	4.528		
	-235-6D-C	○	○						4.528	7.087		
KGDF%	-25-6D-C	○	○	2.612	1.260	0.197	0.236 (6mm)	GDFM 6020N-040GM GDFM 6020N-080GM GDFM 6020N-040GH GDFM 6020N-080GH GDFM 6020N-040DM GDFMS 6020N-040DM GDFM 6020N-300R-CM				
	-35-6D-C	○	○						0.984	1.378		
	-50-6D-C	○	○						1.378	1.969		
	-75-6D-C	○	○						1.969	2.953		
	-115-6D-C	○	○						2.953	4.528		
	-180-6D-C	○	○						4.528	7.087		
-235-6D-C	○	○	7.087	9.252								

● : U.S. Stock ○ : World Express (Shipping: 7-10 Business Days)

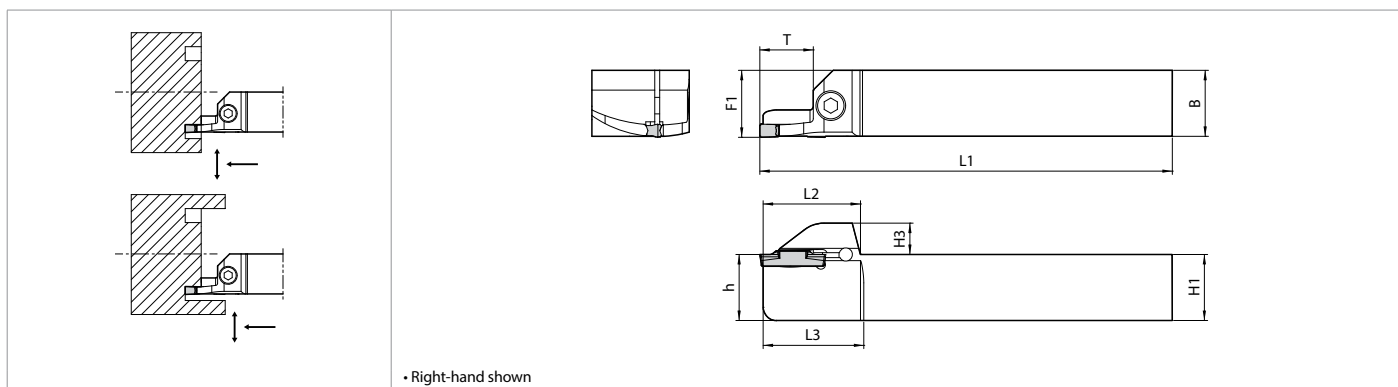



Toolholder Dimensions (3mm / 4mm / 5mm Insert Width)

Insert Width (mm)	Shank Size (mm)	Max. Grooving Depth (mm)	Face Grooving Dia. ØD (mm)		Part Number	Stock		Dimensions (mm)							
			MIN.	MAX.		R	L	H1=h	H3	B	L1	L2	L3	F1	T
3	□20	15	50	65	KGDF <sup>R/L</sup> 2020K50-3B-Z	○	○	20	9.5	20	125	30.5	31	20.3	15
			65	85		○	○								
			85	110		○	○								
			110	145		○	○								
	□25		50	65	KGDF <sup>R/L</sup> 2525M50-3B-Z	○	○	25	9.5	25	150	30.5	31	25.3	15
			65	85		○	○								
			85	110		○	○								
			110	145		○	○								
4	□20	15	50	70	KGDF <sup>R/L</sup> 2020K50-4B-Z	○	○	20	9.5	20	125	30.5	31	20.3	15
			70	100		○	○								
			100	150		○	○								
			50	70		KGDF <sup>R/L</sup> 2525M50-4B-Z	○								
	70		100	○	○										
	100		150	○	○										
	50		75	KGDF <sup>R/L</sup> 2020K50-5B-Z	○		○	20	9.5	20	125	30.5	31	20.3	15
	75		115		○	○									
115	180	○	○												
50	75	KGDF <sup>R/L</sup> 2525M50-5B-Z	○		○	25	9.5								
75	115		○	○											
115	180		○	○											
75	115		KGDF <sup>R/L</sup> 2525M75-5B-Z	○	○			25	9.5	25	150	30.5	31	25.3	15
115	180	○		○											

○ : World Express (Shipping: 7-10 Business Days)

Applicable Inserts See [Page 22](#)

## Spare Parts

Part Number	Spare Parts	
	Clamp Screw	Wrench
		
KGDF <sup>R/L</sup> ...-Z	HH5X16	LW-4

## Toolholder Identification System

<b>KGDF</b>	<b>R</b>	<b>2525</b>	<b>M</b>	<b>50</b>	<b>3</b>	<b>B</b>	<b>Z</b>
Series	Hand of Tool	Shank Size	Toolholder Length	Min. Face Grooving Dia.	Insert Width	Grooving Depth	Toolholder Type
KGDF Face Grooving	R : Right-hand L : Left-hand	2020 : □ 20mm 2525 : □ 25mm	K : 125mm M : 150mm	50 : 50mm ∴ 115 : 115mm	3 : 3mm 4 : 4mm 5 : 5mm	B : 15mm	Z : Integral Type

# KGDF | Face Grooving / 90° SwitchBlade (Inch Size)

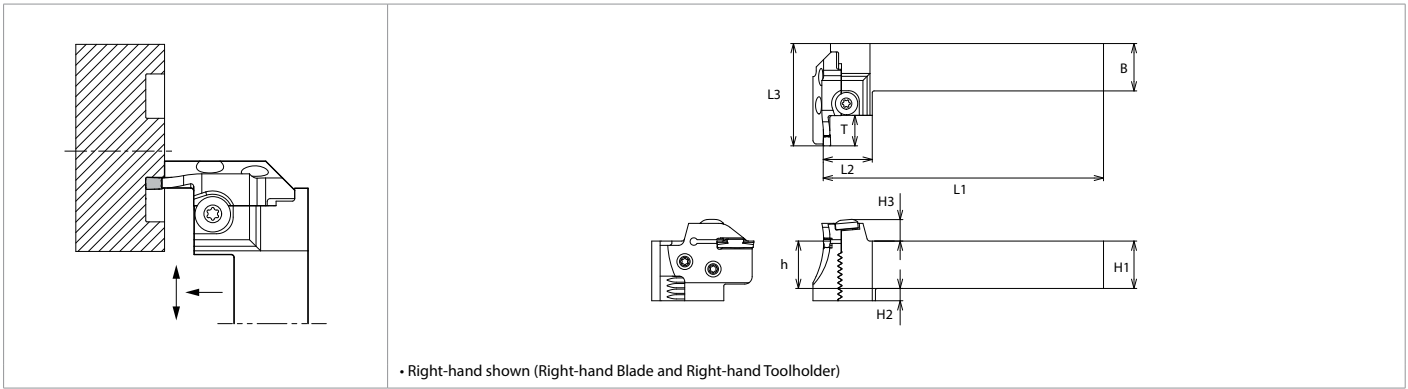

## Toolholder Dimensions (0.079" Insert Width)

Shank Angle	Insert Width W (in)	Shank Size (in)	Max. Grooving Depth (in)	Face Grooving Dia. ØD (in)		Unit Part Number (Toolholder + Blade)	Toolholder Part Number <b>P13</b>	Stock		Blade Part Number <b>P33</b>	Stock		Dimensions (in)								
				MIN.	MAX.			R	L		R	L	H1=h	H2	H3	B	L1	L2	L3	T	
90°	0.079 (2mm)	0.75	0.236 (6mm)	0.984	1.181	No Unit Part Number ➡	KGDSR12-C	●		KGDFR -25-2A-C	○										
				1.181	1.378																
				1.378	1.772																
				1.772	2.362																
				2.362	3.150																
				3.150	3.937																
				3.937	5.118																
	0.079 (2mm)	1.00	0.236 (6mm)	0.984	1.181	No Unit Part Number ➡	KGDSR16-C	●		KGDFR -25-2A-C	○										
				1.181	1.378																
				1.378	1.772																
				1.772	2.362																
				2.362	3.150																
				3.150	3.937																
				3.937	5.118																

● : U.S. Stock ○ : World Express (Shipping: 7-10 Business Days)  
Applicable Inserts See [Page 22](#)

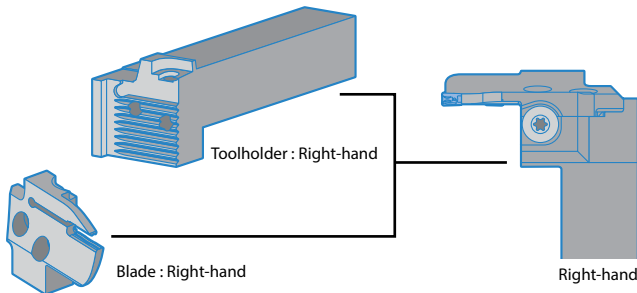

- KGDF 90° SwitchBlade type is not available as unit (toolholder + blade). Blade and toolholder are available to assemble when purchasing individually.
- **Right-hand** Blade for **Right-hand** Toolholder, **Left-hand** Blade for **Left-hand** Toolholder.
- Insert clamp screw (BH6X10TR), Blade fixing screw (SB-60120TR) and Wrench (LTW-25) come with toolholder.

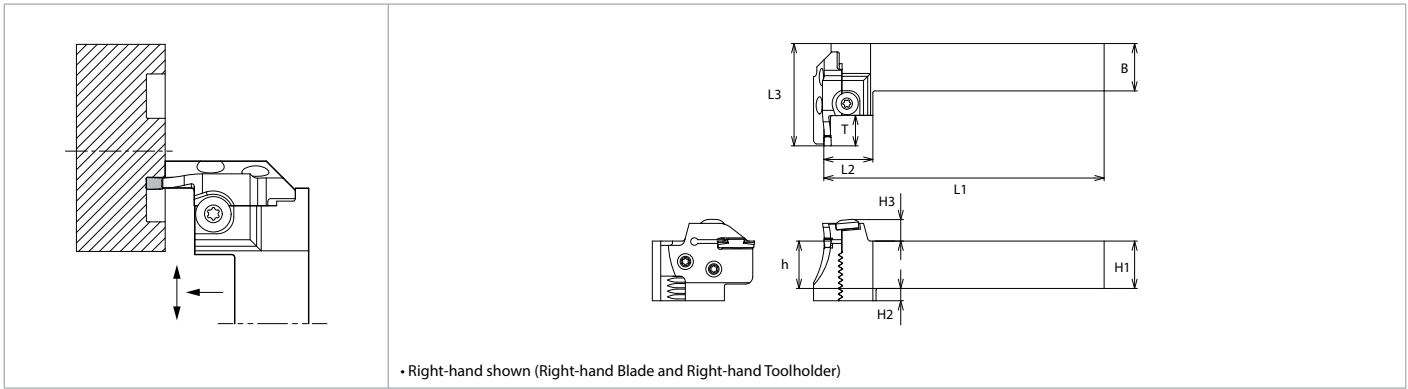

Toolholder Dimensions (0.118" Insert Width)

Shank Angle	Insert Width W (in)	Shank Size (in)	Max. Grooving Depth (in)	Face Grooving Dia. ØD (in)		Unit Part Number (Toolholder + Blade)	Toolholder Part Number P13	Stock		Blade Part Number P33	Stock		Dimensions (in)														
				MIN.	MAX.			R	L		R	L	H1=h	H2	H3	B	L1	L2	L3	T							
90°	0.118 (3mm)	□ 0.75	0.512 (13mm)	0.984	1.181	No Unit Part Number →	KGDS 1/2 12-C	●	●	KGDF 1/2 -25-3A-C	●	●	0.750	0.510	0.457	0.750	4.921	0.988	2.075	0.512							
				1.181	1.575					-30-3A-C	●	●															
				1.575	1.969					-40-3A-C	○	○															
			0.591 (15mm)	1.969	2.559					-50-3B-C	●	○															
				2.559	3.346					-65-3B-C	●	●															
				3.346	4.331					-85-3B-C	●	○															
		0.866 (22mm)	4.331	5.709	-110-3B-C					○	●																
			1.969	2.559	KGDF 1/2 -50-3C-C					○	●	0.750									0.510	0.457	0.750	4.921	0.988	2.350	0.866
			2.559	3.346	-65-3C-C					○	●																
		3.346	4.331	-85-3C-C	○					●																	
		0.984 (25mm)	4.331	5.709	-110-3C-C					●	●																
			0.984	1.181	KGDF 1/2 -25-3A-C					●	●																
	0.512 (13mm)		1.181	1.575	-30-3A-C	●	●																				
		1.575	1.969	-40-3A-C	○	○																					
		0.591 (15mm)	1.969	2.559	-50-3B-C	●	○																				
	2.559		3.346	-65-3B-C	●	●																					
	3.346		4.331	-85-3B-C	●	○																					
	0.866 (22mm)	4.331	5.709	-110-3B-C	○	●																					
		1.969	2.559	KGDF 1/2 -50-3C-C	○	●	1.000	0.260	0.457	1.000	5.906		0.988	2.350	0.866												
		0.512 (13mm)	1.181	1.575	-65-3C-C	○						●															
	1.575		1.969	-85-3C-C	○	●																					
	0.591 (15mm)		1.969	2.559	-110-3C-C	●						●															
		2.559	3.346	KGDF 1/2 -25-3A-C	●	●						1.000				0.260	0.457	1.000	5.906	0.988	2.429	0.984					
		0.866 (22mm)	3.346	4.331	-30-3A-C	●																	●				
4.331	5.709		-40-3A-C	○	○																						
0.984 (25mm)	1.969		2.559	-50-3B-C	●	○																					
	2.559	3.346	-65-3B-C	●	●																						
	3.346	4.331	-85-3B-C	●	○																						
0.984 (25mm)	4.331	5.709	-110-3B-C	○	●																						
	1.969	2.559	KGDF 1/2 -50-3C-C	○	●	1.000																	0.260	0.457	1.000	5.906	0.988
	0.512 (13mm)	1.181	1.575	-65-3C-C	○		●																				
1.575		1.969	-85-3C-C	○	●																						
0.591 (15mm)		1.969	2.559	-110-3C-C	●		●																				

• KGDF 90° SwitchBlade type is not available as unit (toolholder + blade).  
Blade and toolholder are available to assemble when purchasing individually.

● : U.S. Stock ○ : World Express (Shipping: 7-10 Business Days)

Applicable Inserts See [Page 22](#)

• **Right-hand** Blade for **Right-hand** Toolholder, **Left-hand** Blade for **Left-hand** Toolholder.

• Insert clamp bolt (BH6x10TR) and Blade fixing bolt (SB-60120TR) and Wrench (LTW-25) come with toolholder. For Spare Parts, see [Page 31](#)



# KGDF | Face Grooving / 90° SwitchBlade (Inch Size)

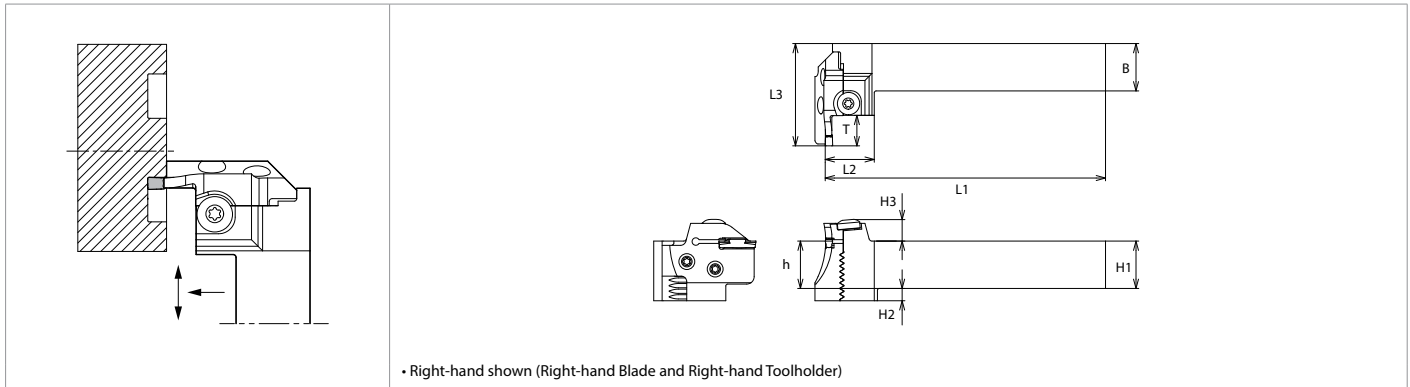

## Toolholder Dimensions (0.157" Insert Width)

Shank Angle	Insert Width W (in)	Shank Size (in)	Max. Grooving Depth (in)	Face Grooving Dia. ØD (in)		Unit Part Number (Toolholder + Blade)	Toolholder Part Number P13	Stock		Blade Part Number P33	Stock		Dimensions (in)							
				MIN.	MAX.			R	L		R	L	H1=h	H2	H3	B	L1	L2	L3	T
90°	0.157 (4mm)	0.75	0.512 (13mm)	0.984	1.378	No Unit Part Number ➔	KGDS <sup>R/L</sup> 12-C	●	●	KGDF <sup>R/L</sup> -25-4A-C	●	●	0.750	0.510	0.457	0.750	4.921	0.988	2.075	0.512
			1.378	1.969	KGDF <sup>R/L</sup> -35-4B-C			○	○											
			1.969	2.756	-50-4B-C			●	●											
			0.591 (15mm)	2.756	3.937			-70-4B-C	●	●										
			3.937	5.906	-100-4B-C			●	●											
			5.906	8.661	-150-4B-C			○	○											
		8.661	∞	-220-4B-C	○			○												
		1.378	1.969	KGDF <sup>R/L</sup> -35-4C-C	○			○												
		1.969	2.756	-50-4C-C	○			●												
		0.984 (25mm)	2.756	3.937	-70-4C-C			●	○											
		3.937	5.906	-100-4C-C	○			●												
		5.906	8.661	-150-4C-C	●			○												
	8.661	∞	-220-4C-C	○	○															
	0.512 (13mm)	0.984	1.378	No Unit Part Number ➔	KGDS <sup>R/L</sup> 16-C	●	●	KGDF <sup>R/L</sup> -25-4A-C	●	●	1.000	0.260	0.457	1.000	5.906	0.988	2.075	0.512		
	1.378	1.969	KGDF <sup>R/L</sup> -35-4B-C			○	○													
	1.969	2.756	-50-4B-C			●	●													
	0.591 (15mm)	2.756	3.937			-70-4B-C	●	●												
	3.937	5.906	-100-4B-C			●	●													
	5.906	8.661	-150-4B-C			○	○													
	8.661	∞	-220-4B-C			○	○													
	1.378	1.969	KGDF <sup>R/L</sup> -35-4C-C			○	○													
	1.969	2.756	-50-4C-C			○	●													
	0.984 (25mm)	2.756	3.937			-70-4C-C	●	○												
	3.937	5.906	-100-4C-C			○	●													
5.906	8.661	-150-4C-C	●			○														
8.661	∞	-220-4C-C	○	○																

• KGDF 90° SwitchBlade type is not available as unit (toolholder + blade).  
Blade and toolholder are available to assemble when purchasing individually.

● : U.S. Stock ○ : World Express (Shipping: 7-10 Business Days)  
Applicable Inserts See [Page 22](#)

• **Right-hand** Blade for **Right-hand** Toolholder, **Left-hand** Blade for **Left-hand** Toolholder.

• Insert clamp bolt (BH6x10TR) and Blade fixing bolt (SB-60120TR) and Wrench (LTW-25) come with toolholder. For Spare Parts, see [Page 31](#)

# KGDF | Face Grooving / 90° SwitchBlade (Inch Size)

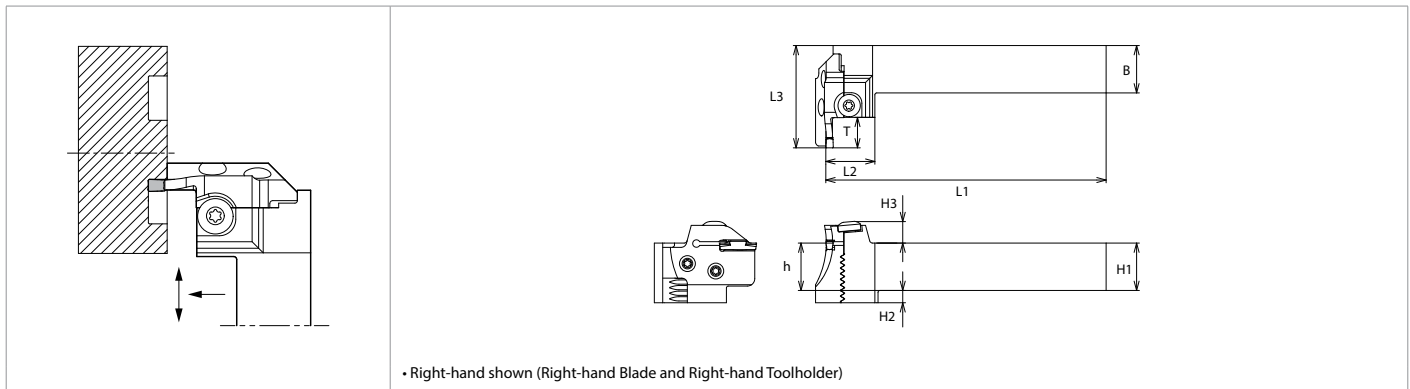

## Toolholder Dimensions (0.197" Insert Width)

Shank Angle	Insert Width W (in)	Shank Size (in)	Max. Grooving Depth (in)	Face Grooving Dia. ØD (in)		Unit Part Number (Toolholder + Blade)	Toolholder Part Number P13	Stock		Blade Part Number P33	Stock		Dimensions (in)															
				MIN.	MAX.			R	L		R	L	H1=h	H2	H3	B	L1	L2	L3	T								
90°	0.197 (5mm)	□ 0.75	0.591 (15mm)	0.984	1.378	No Unit Part Number →	KGDS 12-C	●	●	KGDF 25-5B-C	●	●	0.750	0.510	0.457	0.750	4.921	0.927	2.154	0.591								
				1.378	1.969					-35-5B-C	○	●																
				1.969	2.953					-50-5B-C	●	○																
				2.953	4.528					-75-5B-C	○	●																
				4.528	7.087					-115-5B-C	●	●																
				7.087	9.252					-180-5B-C	●	○																
			9.252	∞	-235-5B-C					●	●																	
			0.787 (20mm)	0.984	1.378					KGDF 25-5C-C	○	●									0.750	0.510	0.457	0.750	4.921	0.927	2.35	0.787
			1.378	1.969	-35-5C-C					●	●	0.750									0.510	0.457	0.750	4.921	0.927	2.547	0.984	
			1.969	2.953	-50-5C-C					○	●																	
			2.953	4.528	-75-5C-C					○	●																	
			4.528	7.087	-115-5C-C					○	●																	
		7.087	9.252	-180-5C-C	●	●																						
		9.252	∞	-235-5C-C	●	●																						
		1.260 (32mm)	2.953	4.528	KGDF 75-5D-C	○	●	0.750	0.510	0.457	0.750	4.921	0.927	2.823	1.26													
		4.528	7.087	-115-5D-C	○	○	0.750	0.510	0.457	0.750	4.921	0.927	2.823	1.26														
		7.087	9.252	-180-5D-C	●	●																						
		9.252	∞	-235-5D-C	○	●																						
		□ 1.00	0.591 (15mm)	0.984	1.378	No Unit Part Number →	KGDS 16-C	●	●	KGDF 25-5B-C	●	●	1.000	0.260	0.457	1.000	5.906	1.177	2.154	0.591								
				1.378	1.969					-35-5B-C	○	●																
				1.969	2.953					-50-5B-C	●	○																
				2.953	4.528					-75-5B-C	○	●																
				4.528	7.087					-115-5B-C	●	●																
7.087	9.252			-180-5B-C	●					○																		
9.252	∞		-235-5B-C	●	●																							
0.787 (20mm)	0.984		1.378	KGDF 25-5C-C	○					●	1.000	0.260									0.457	1.000	5.906	1.177	2.35	0.787		
1.378	1.969		-35-5C-C	●	●					1.000	0.260	0.457									1.000	5.906	1.177	2.547	0.984			
1.969	2.953		-50-5C-C	○	●																							
2.953	4.528		-75-5C-C	○	●																							
4.528	7.087		-115-5C-C	○	●																							
7.087	9.252	-180-5C-C	●	●																								
9.252	∞	-235-5C-C	●	●																								
1.260 (32mm)	2.953	4.528	KGDF 75-5D-C	○	●	1.000	0.260	0.457	1.000	5.906	1.177	2.823	1.26															
4.528	7.087	-115-5D-C	○	○	1.000	0.260	0.457	1.000	5.906	1.177	2.823	1.26																
7.087	9.252	-180-5D-C	●	●																								
9.252	∞	-235-5D-C	○	●																								

• KGDF 90° SwitchBlade type is not available as unit (toolholder + blade).

● : U.S. Stock ○ : World Express (Shipping: 7-10 Business Days)

Blade and toolholder are available to assemble when purchasing individually.

Applicable Inserts See [Page 22](#)

• **Right-hand** Blade for **Right-hand** Toolholder, **Left-hand** Blade for **Left-hand** Toolholder.

• Insert clamp bolt (BH6x10TR) and Blade fixing bolt (SB-60120TR) and Wrench (LTW-25) come with toolholder. For Spare Parts, see [Page 31](#)

# KGDF | Face Grooving / 90° SwitchBlade (Inch Size)

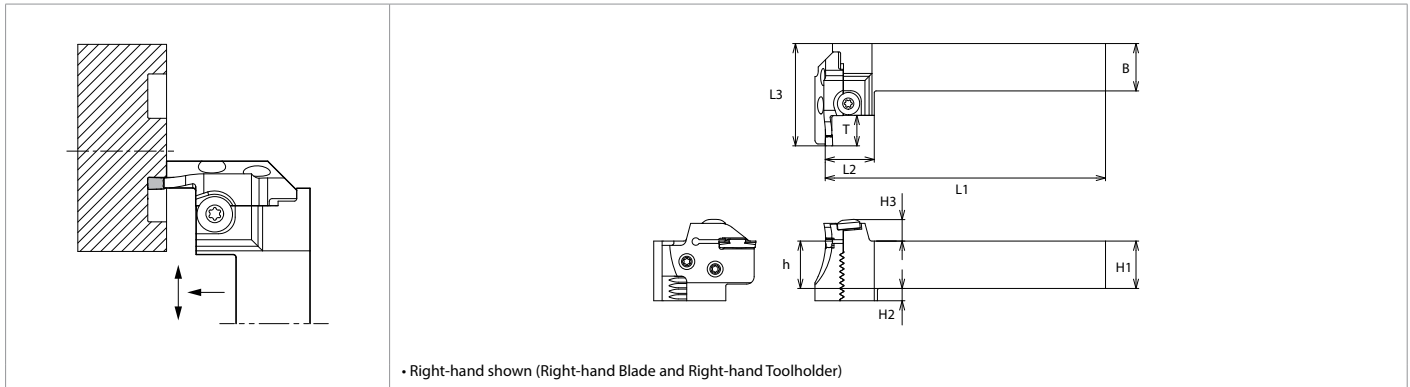

## Toolholder Dimensions (0.236" Insert Width)

Shank Angle	Insert Width W (in)	Shank Size (in)	Max. Grooving Depth (in)	Face Grooving Dia. ØD (in)		Unit Part Number (Toolholder + Blade)	Toolholder Part Number P13	Stock		Blade Part Number P33	Stock		Dimensions (in)							
				MIN.	MAX.			R	L		R	L	H1=h	H2	H3	B	L1	L2	L3	T
90°	0.236 (6mm)	0.75	0.591 (15mm)	0.984	1.378	No Unit Part Number →	KGDS% 12-C	●	●	KGDF% -25-6B-C	●	●	0.750	0.510	0.457	0.750	4.921	0.988	2.154	0.591
				1.378	1.969					-35-6B-C	●	●								
				1.969	2.953					-50-6B-C	○	●								
				2.953	4.528					-75-6B-C	●	●								
				4.528	7.087					-115-6B-C	●	●								
				7.087	9.252					-180-6B-C	●	●								
			9.252	∞	-235-6B-C					○	●									
			0.787 (20mm)	0.984	1.378					KGDF% -25-6C-C	●	●	0.750	0.510	0.457	0.750	4.921	0.988	2.350	0.787
			1.378	1.969	-35-6C-C					●	●	0.750	0.510	0.457	0.750	4.921	0.988	2.547	0.984	
			1.969	2.953	-50-6C-C					●	●									
			2.953	4.528	-75-6C-C					○	●									
			4.528	7.087	-115-6C-C					●	●									
		7.087	9.252	-180-6C-C	●	●														
		9.252	∞	-235-6C-C	●	●														
		1.260 (32mm)	2.953	4.528	KGDF% -75-6D-C	●	●	0.750	0.510	0.457	0.750	4.921	0.988	2.823	1.260					
		4.528	7.087	-115-6D-C	●	●	0.750	0.510	0.457	0.750	4.921	0.988	2.823	1.260						
		7.087	9.252	-180-6D-C	●	●														
		9.252	∞	-235-6D-C	●	●														
		1.00	0.591 (15mm)	0.984	1.378	No Unit Part Number →	KGDS% 16-C	●	●	KGDF% -25-6B-C	●	●	1.000	0.260	0.457	1.000	5.906	0.988	2.154	0.591
				1.378	1.969					-35-6B-C	●	●								
				1.969	2.953					-50-6B-C	○	●								
				2.953	4.528					-75-6B-C	●	●								
				4.528	7.087					-115-6B-C	●	●								
7.087	9.252			-180-6B-C	●					●										
9.252	∞		-235-6B-C	○	●															
0.787 (20mm)	0.984		1.378	KGDF% -25-6C-C	●					●	1.000	0.260	0.457	1.000	5.906	0.988	2.350	0.787		
1.378	1.969		-35-6C-C	●	●					1.000	0.260	0.457	1.000	5.906	0.988	2.547	0.984			
1.969	2.953		-50-6C-C	●	●															
2.953	4.528		-75-6C-C	○	●															
4.528	7.087		-115-6C-C	●	●															
7.087	9.252	-180-6C-C	●	●																
9.252	∞	-235-6C-C	●	●																
1.260 (32mm)	2.953	4.528	KGDF% -75-6D-C	●	●	1.000	0.260	0.457	1.000	5.906	0.988	2.823	1.260							
4.528	7.087	-115-6D-C	●	●	1.000	0.260	0.457	1.000	5.906	0.988	2.823	1.260								
7.087	9.252	-180-6D-C	●	●																
9.252	∞	-235-6D-C	●	●																

- KGDF 90° SwitchBlade type is not available as unit (toolholder + blade). Blade and toolholder are available to assemble when purchasing individually.
  - **Right-hand** Blade for **Right-hand** Toolholder, **Left-hand** Blade for **Left-hand** Toolholder.
  - Insert clamp bolt (BH6x10TR) and Blade fixing bolt (SB-60120TR) and Wrench (LTW-25) come with toolholder. For Spare Parts, see [Page 31](#)
- : U.S. Stock ○ : World Express (Shipping: 7-10 Business Days)  
Applicable Inserts See [Page 22](#)

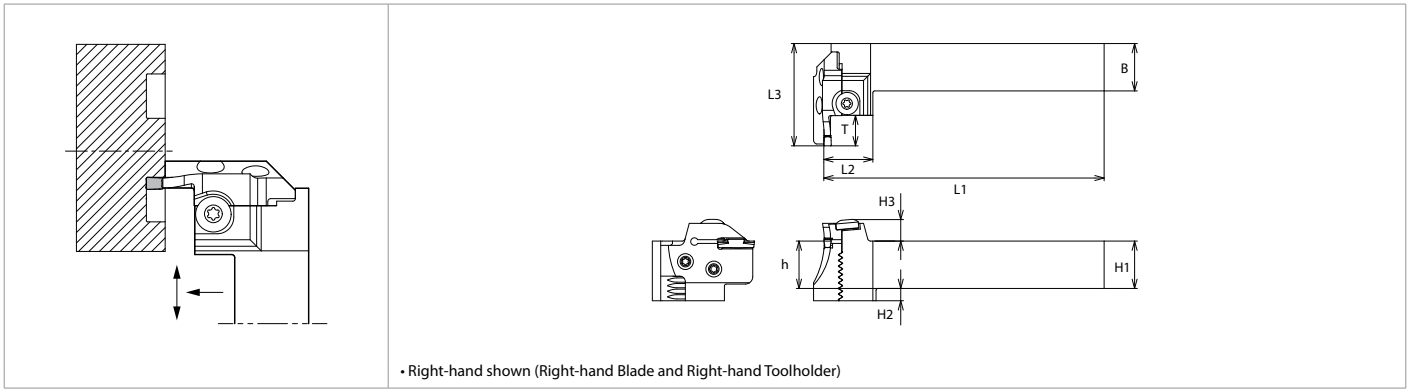

Toolholder Dimensions (2mm Insert Width)

Shank Angle	Insert Width W (mm)	Shank Size (mm)	Max. Grooving Depth (mm)	Face Grooving Dia. ØD (mm)		Unit Part Number (Toolholder + Blade)	Toolholder Part Number P13	Stock		Blade Part Number P33	Stock		Dimensions (mm)								
				MIN.	MAX.			R	L		R	L	H1=h	H2	H3	B	L1	L2	L3	T	
90°	2	□20	6	25	30	No Unit Part Number ➔	KGDSR2020-C	○		KGDFR -25-2A-C	○		20	12	11.6	20	125	27.7	49.7	6	
				30	35					-30-2A-C											○
				35	45					-35-2A-C											●
				45	60					-45-2A-C											○
				60	80					-60-2A-C											○
				80	100					-80-2A-C											○
				100	130					-100-2A-C											○
	2	□25	6	25	30	No Unit Part Number ➔	KGDSR2525-C	○		KGDFR -25-2A-C	○		25	7	11.6	25	150	27.7	49.7	6	
				30	35					-30-2A-C											○
				35	45					-35-2A-C											●
				45	60					-45-2A-C											○
				60	80					-60-2A-C											○
				80	100					-80-2A-C											○
				100	130					-100-2A-C											○

- KGDF 90° SwitchBlade type is not available as unit (toolholder + blade). Blade and toolholder are available to assemble when purchasing individually.
  - **Right-hand** Blade for **Right-hand** Toolholder, **Left-hand** Blade for **Left-hand** Toolholder.
  - Insert clamp bolt (BH6x10TR) and Blade fixing bolt (SB-60120TR) and Wrench (LTW-25) come with toolholder. For Spare Parts, see [Page 31](#)
- : U.S. Stock ○ : World Express (Shipping: 7-10 Business Days)  
 Applicable Inserts See [Page 22](#)

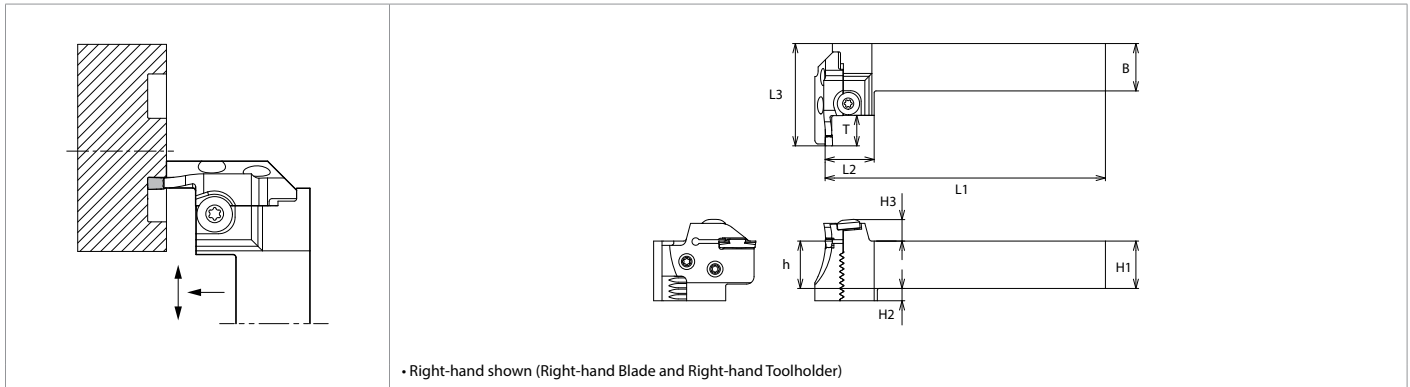

Toolholder Dimensions (3mm Insert Width)

Shank Angle	Insert Width W (mm)	Shank Size (mm)	Max. Grooving Depth (mm)	Face Grooving Dia. ØD (mm)		Unit Part Number (Toolholder + Blade)	Toolholder Part Number <b>P13</b>	Stock		Blade Part Number <b>P33</b>	Stock		Dimensions (mm)							
				MIN.	MAX.			R	L		R	L	H1=h	H2	H3	B	L1	L2	L3	T
90°	3	□20	13	25	30	No Unit Part Number ➔	KGDS %L 2020-C	○	○	KGDF %L -25-3A-C	●	●	20	12	11.6	20	125	27.7	52.7	13
				-30-3A-C	●					●										
				-40-3A-C	○					○										
			15	50	65					KGDF %L -50-3B-C	●	○	20	12	11.6	20	125	27.7	54.7	15
				65	85					-65-3B-C	●	●								
				85	110					-85-3B-C	●	○								
		22	50	65	KGDF %L -50-3C-C					○	●	20	12	11.6	20	125	27.7	59.7	22	
			65	85	-65-3C-C					○	●									
			85	110	-85-3C-C					○	●									
		25	85	110	-110-3B-C					○	●	20	12	11.6	20	125	27.7	61.7	25	
			110	145	-110-3C-C					●	●									
	3	□25	13	25	30	No Unit Part Number ➔	KGDS %L 2525-C	○	○	KGDF %L -25-3A-C	●	●	25	7	11.6	25	150	27.7	52.7	13
				30	40					-30-3A-C	●	●								
				40	50					-40-3A-C	○	○								
			15	50	65					-50-3B-C	●	○	25	7	11.6	25	150	27.7	54.7	15
				65	85					-65-3B-C	●	●								
				85	110					-85-3B-C	●	○								
		22	50	65	KGDF %L -50-3C-C					○	●	25	7	11.6	25	150	27.7	59.7	22	
			65	85	-65-3C-C					○	●									
			85	110	-85-3C-C					○	●									
		25	85	110	KGDF %L -85-3C-C					○	●	25	7	11.6	25	150	27.7	61.7	25	
			110	145	-110-3C-C					●	●									

• KGDF 90° SwitchBlade type is not available as unit (toolholder + blade).

Blade and toolholder are available to assemble when purchasing individually.

• **Right-hand** Blade for **Right-hand** Toolholder, **Left-hand** Blade for **Left-hand** Toolholder.

• Insert clamp bolt (BH6x10TR) and Blade fixing bolt (SB-60120TR) and Wrench (LTW-25) come with toolholder. For Spare Parts, see **Page 31**

● : U.S. Stock ○ : World Express (Shipping: 7-10 Business Days)

Applicable Inserts See **Page 22**

# KGDF | Face Grooving / 90° SwitchBlade (Metric Size)

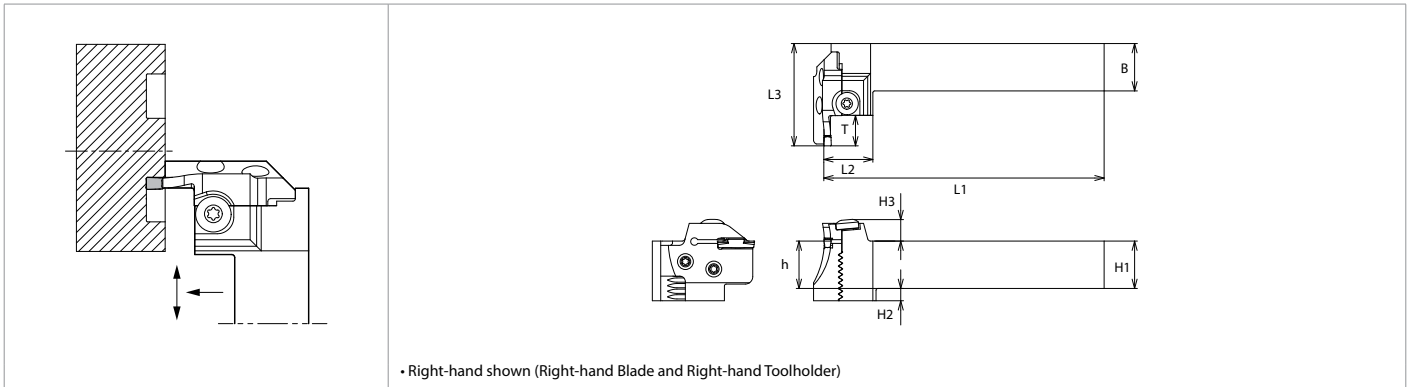

## Toolholder Dimensions (4mm Insert Width)

Shank Angle	Insert Width W (mm)	Shank Size (mm)	Max. Grooving Depth (mm)	Face Grooving Dia. ØD (mm)		Unit Part Number (Toolholder + Blade)	Toolholder Part Number ➔ P13	Stock		Blade Part Number ➔ P33	Stock		Dimensions (mm)											
				MIN.	MAX.			R	L		R	L	H1=h	H2	H3	B	L1	L2	L3	T				
90°	4	□20	13	25	35	No Unit Part Number ➔	KGDS%L2020-C	○	○	KGDF%L-25-4A-C	●	●	20	12	11.6	20	125	27.7	52.7	13				
				-35-4B-C	○					○														
			50	70	-50-4B-C					●	●													
			70	100	-70-4B-C					●	●	20	12	11.6	20	125	27.7	54.7	15					
			100	150	-100-4B-C					●	●													
			150	220	-150-4B-C					○	○													
		25	220	∞	-220-4B-C					○	○													
			35	50	KGDF%L-35-4C-C					○	○													
			50	70	-50-4C-C					○	●													
			70	100	-70-4C-C					●	○	20	12	11.6	20	125	27.7	64.7	25					
			100	150	-100-4C-C					○	●													
			150	220	-150-4C-C					●	○													
	4	□25	13	25	35	No Unit Part Number ➔	KGDS%L2525-C	○	○	KGDF%L-25-4A-C	●	●	25	7	11.6	25	150	27.7	52.7	13				
				-35-4B-C	○					○														
			50	70	-50-4B-C					●	●													
			70	100	-70-4B-C					●	●	25	7	11.6	25	150	27.7	54.7	15					
			100	150	-100-4B-C					●	●													
			150	220	-150-4B-C					○	○													
		25	220	∞	-220-4B-C					○	○													
			35	50	KGDF%L-35-4C-C					○	○													
			50	70	-50-4C-C					○	●													
			70	100	-70-4C-C					●	○	25	7	11.6	25	150	27.7	64.7	25					
			100	150	-100-4C-C					○	●													
			150	220	-150-4C-C					●	○													
		220	∞	-220-4C-C	○	○																		

• KGDF 90° SwitchBlade type is not available as unit (toolholder + blade).  
Blade and toolholder are available to assemble when purchasing individually.

● : U.S. Stock ○ : World Express (Shipping: 7-10 Business Days)

Applicable Inserts See ➔ Page 22

• **Right-hand** Blade for **Right-hand** Toolholder, **Left-hand** Blade for **Left-hand** Toolholder.

• Insert clamp bolt (BH6x10TR) and Blade fixing bolt (SB-60120TR) and Wrench (LTW-25) come with toolholder. For Spare Parts, see ➔ Page 31

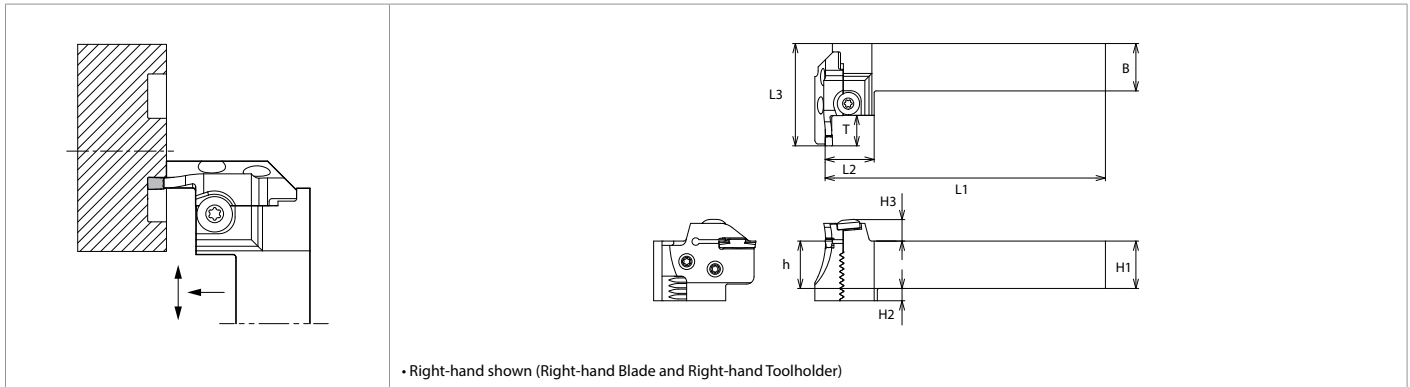

Toolholder Dimensions (5mm Insert Width)

Shank Angle	Insert Width W (mm)	Shank Size (mm)	Max. Grooving Depth (mm)	Face Grooving Dia. ØD (mm)		Unit Part Number (Toolholder + Blade)	Toolholder Part Number P13	Stock		Blade Part Number P33	Stock		Dimensions (mm)																
				MIN.	MAX.			R	L		R	L	H1=h	H2	H3	B	L1	L2	L3	T									
90°	5	□20	15	25	35	No Unit Part Number ➔	KGDS %L 2020-C	○	○	KGDF %L -25-5B-C	●	●	20	12	11.6	20	125	27.7	54.7	15									
				35	50					KGDF %L -35-5B-C	○	●																	
				50	75					KGDF %L -50-5B-C	●	○																	
				75	115					KGDF %L -75-5B-C	○	●																	
				115	180					KGDF %L -115-5B-C	●	●																	
				180	235					KGDF %L -180-5B-C	●	○																	
			235	∞	KGDF %L -235-5B-C					●	●																		
			20	25	35					KGDF %L -25-5C-C	○	●									20	12	11.6	20	125	27.7	59.7	20	
				35	50					KGDF %L -35-5C-C	●	●																	
				50	75					KGDF %L -50-5C-C	○	●																	
				75	115					KGDF %L -75-5C-C	○	●																	
				115	180					KGDF %L -115-5C-C	○	●																	
		180		235	KGDF %L -180-5C-C	●	●																						
		25	75	115	KGDF %L -75-5D-C	○	●	20	12	11.6	20	125	27.7	64.7	25														
			115	180	KGDF %L -115-5D-C	○	○																						
			180	235	KGDF %L -180-5D-C	●	●																						
			235	∞	KGDF %L -235-5D-C	○	●																						
			□25	15	25	35	No Unit Part Number ➔									KGDS %L 2525-C	○	○	KGDF %L -25-5B-C	●	●	25	7	11.6	25	150	27.7	54.7	15
					35	50													KGDF %L -35-5B-C	○	●								
		50			75	KGDF %L -50-5B-C		●	○																				
		75			115	KGDF %L -75-5B-C		○	●																				
		115			180	KGDF %L -115-5B-C		●	●																				
		180			235	KGDF %L -180-5B-C		●	○																				
		235		∞	KGDF %L -235-5B-C	●		●																					
20	25	35		KGDF %L -25-5C-C	○	●		25	7	11.6	25	150	27.7	59.7	20														
	35	50		KGDF %L -35-5C-C	●	●																							
	50	75		KGDF %L -50-5C-C	○	●																							
	75	115		KGDF %L -75-5C-C	○	●																							
	115	180		KGDF %L -115-5C-C	○	●																							
	180	235	KGDF %L -180-5C-C	●	●																								
25	75	115	KGDF %L -75-5D-C	○	●	25	7	11.6	25	150	27.7	64.7	25																
	115	180	KGDF %L -115-5D-C	○	○																								
	180	235	KGDF %L -180-5D-C	●	●																								
	235	∞	KGDF %L -235-5D-C	○	●																								

• KGDF 90° SwitchBlade type is not available as unit (toolholder + blade).  
 Blade and toolholder are available to assemble when purchasing individually. ● : U.S. Stock ○ : World Express (Shipping: 7-10 Business Days)  
 Applicable Inserts See Page 22  
 • Right-hand Blade for Right-hand Toolholder, Left-hand Blade for Left-hand Toolholder.  
 • Insert clamp bolt (BH6x10TR) and Blade fixing bolt (SB-60120TR) and Wrench (LTW-25) come with toolholder. For Spare Parts, see Page 31

# KGDF | Face Grooving / 90° SwitchBlade (Metric Size)

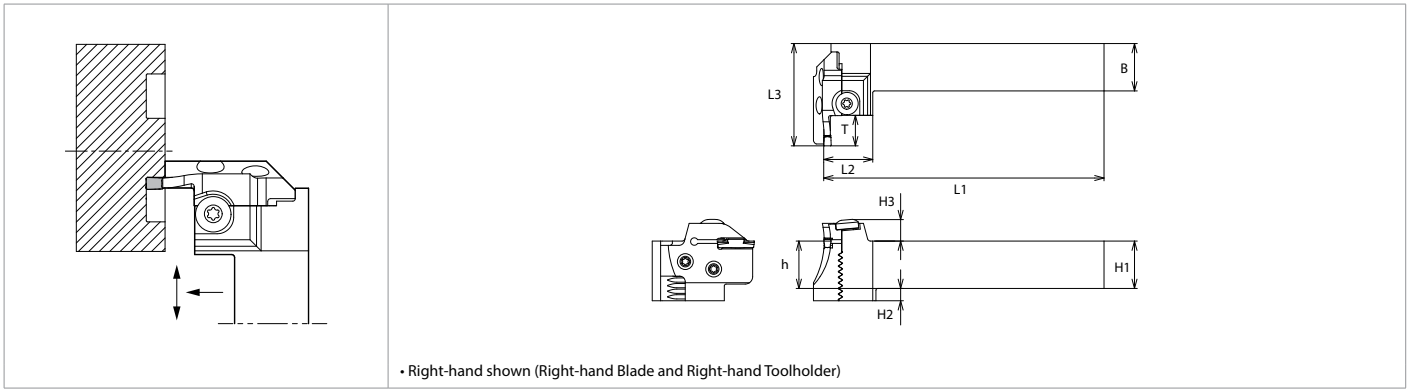

## Toolholder Dimensions (6mm Insert Width)

Shank Angle	Insert Width W (mm)	Shank Size (mm)	Max. Grooving Depth (mm)	Face Grooving Dia. ØD (mm)		Unit Part Number (Toolholder + Blade)	Toolholder Part Number P13	Stock		Blade Part Number P33	Stock		Dimensions (mm)																		
				MIN.	MAX.			R	L		R	L	H1=h	H2	H3	B	L1	L2	L3	T											
90°	6	□20	15	25	35	No Unit Part Number →	KGDS%L2020-C	○	○	KGDF%L-25-6B-C	●	●	20	12	11.6	20	125	27.7	54.7	15											
				35	50			KGDF%L-35-6B-C	●	●																					
				50	75			KGDF%L-50-6B-C	○	●																					
				75	115			KGDF%L-75-6B-C	●	●																					
				115	180			KGDF%L-115-6B-C	●	●																					
				180	235			KGDF%L-180-6B-C	●	●																					
		235	∞	KGDF%L-235-6B-C	○			●																							
		20	25	35	□25			15	No Unit Part Number →	KGDS%L2525-C	○	○	KGDF%L-25-6C-C	●	●	25	7	11.6	25	150	27.7	59.7	20								
		35	50	KGDF%L-35-6C-C							●	●																			
		50	75	KGDF%L-50-6C-C							●	●																			
		75	115	KGDF%L-75-6C-C							○	●																			
		115	180	KGDF%L-115-6C-C							●	●																			
	180	235	KGDF%L-180-6C-C	●		●																									
	235	∞	KGDF%L-235-6C-C	●	●																										
	32	75	115	□25	15	No Unit Part Number →	KGDS%L2525-C	○	○	KGDF%L-75-6D-C	●	●	25	7	11.6	25	150	27.7	64.7	25											
	115	180	KGDF%L-115-6D-C					●	●																						
	180	235	KGDF%L-180-6D-C					●	●																						
	235	∞	KGDF%L-235-6D-C					●	●																						
	75	115	□25					15	No Unit Part Number →	KGDS%L2525-C	○	○									KGDF%L-75-6B-C	●	●	25	7	11.6	25	150	27.7	59.7	20
	35	50									KGDF%L-35-6C-C	●									●										
	50	75		KGDF%L-50-6C-C	●	●																									
	75	115		KGDF%L-75-6C-C	○	●																									
	115	180		KGDF%L-115-6C-C	●	●																									
	180	235		KGDF%L-180-6C-C	●	●																									
235	∞	KGDF%L-235-6C-C	●	●																											
32	75	115	□25	15	No Unit Part Number →	KGDS%L2525-C	○	○	KGDF%L-75-6D-C	●	●	25	7	11.6	25	150	27.7	71.7	32												
115	180	KGDF%L-115-6D-C					●	●																							
180	235	KGDF%L-180-6D-C					●	●																							
235	∞	KGDF%L-235-6D-C					●	●																							

• KGDF 90° SwitchBlade type is not available as unit (toolholder + blade).  
Blade and toolholder are available to assemble when purchasing individually.

● : U.S. Stock ○ : World Express (Shipping: 7-10 Business Days)  
Applicable Inserts See [Page 22](#)

• **Right-hand** Blade for **Right-hand** Toolholder, **Left-hand** Blade for **Left-hand** Toolholder.

• Insert clamp bolt (BH6x10TR) and Blade fixing bolt (SB-60120TR) and Wrench (LTW-25) come with toolholder. For Spare Parts, see [Page 31](#)



Workpiece	Recommended Insert Grade (Vc : sfm)				Notes
	Cermet		MEGACOAT		
	TN620	TN90	PR1225	PR1215	
Carbon Steel	☆ 200 - 660	☆ 260 - 660	★ 200 - 520	☆ 260 - 520	Coolant
Alloy Steel	☆ 200 - 520	☆ 230 - 520	★ 200 - 490	☆ 200 - 490	
Stainless Steel	-	-	★ 160 - 390	☆ 160 - 390	
Cast Iron	-	-	-	★ 260 - 520	

Recommended Cutting Conditions (Feed Rate / D.O.C.)

(Workpiece : 1049)

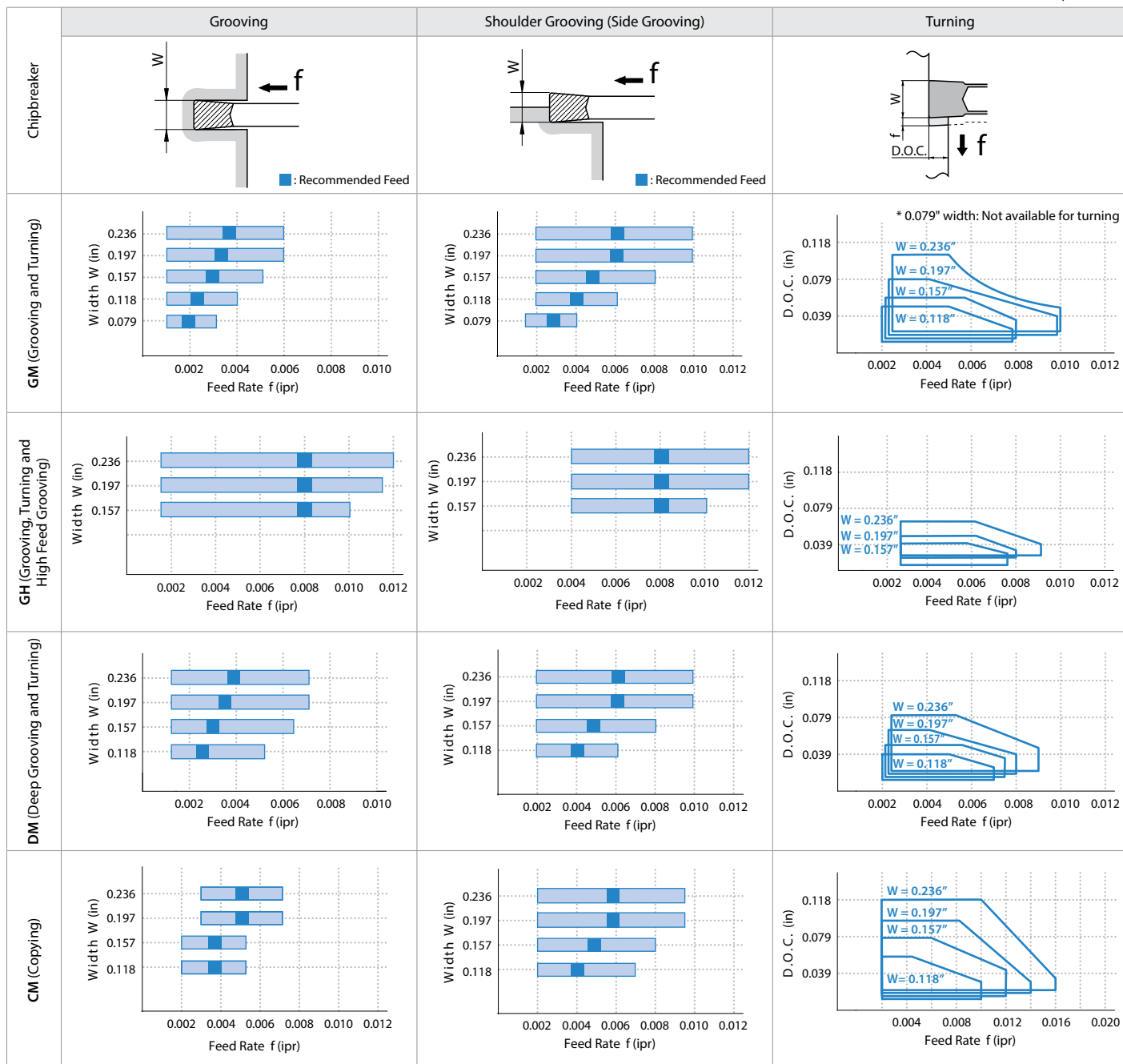

- When shouldering,
- If D.O.C. is set smaller, set feed higher.
  - If D.O.C. is set larger, set feed lower.

1) The above values reflect a T dimension that is 0.591" (15mm) or less.  
When T dimension is over 0.669" (17mm), set the values for turning to less than 90% of recommended cutting conditions above.

# Face Grooving Guide

## 1 Toolholder Selection

Check the range of applicable "face grooving diameter" as well as the groove width and depth.

## 2 Cutting Conditions (Feed Rate : f)

When machining steel, set the feed rate (f) so that chips are created in a helical form when plunging.

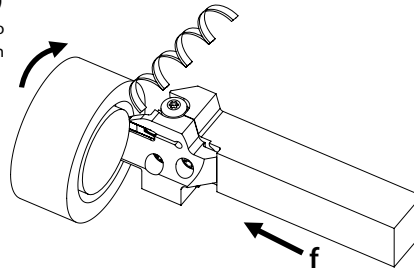

## 3 Expanding Groove Width (Plunging and Turning)

Start machining from the outside and then proceed to the inside to improve chip control.

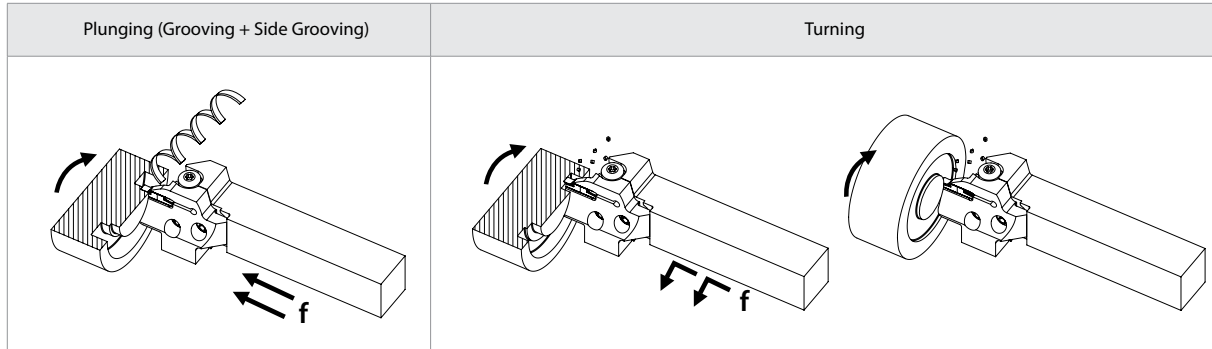

## 4 Guide for Turning

A. When the cutting amount (D.O.C.) is over 0.020" (0.5mm)

- ① Use plunging
- ② Pull back tool by 0.004" (1.0mm)  
(Failure to pull the tool back before turning will result in an unbalanced load applied on only one side of the cutting edge.)
- ③ Perform turning (see Fig.1)

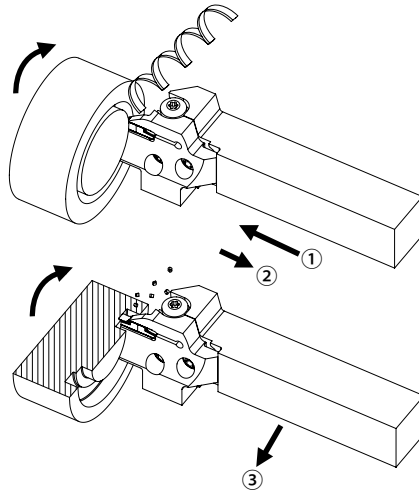
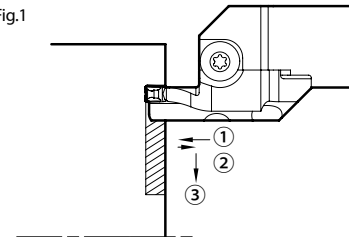

Fig.1



● When Widening the Face Groove Width (see Fig.2)

Use "Step Turning".  
Then perform finishing.

Fig.2

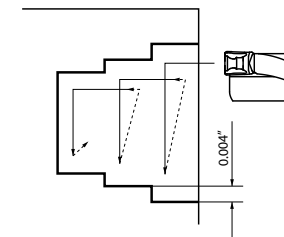

B. When the cutting amount (D.O.C.) is under 0.020" (0.5mm)

- ① Use plunging
- ② Perform turning  
Machining without interruption is possible. (see Fig.3)

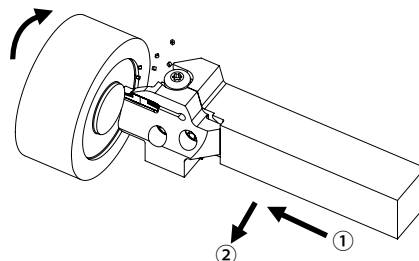
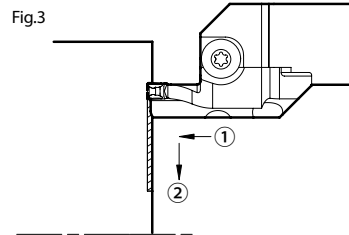

Fig.3



Case Studies

**Gear 5120H (Grooving)**

Vc = 370 ~ 540 sfm  
 f = 0.002 ipr  
 Wet  
 GDM4020N-040GM (PR1225)  
 KGDL2525X-3T10S

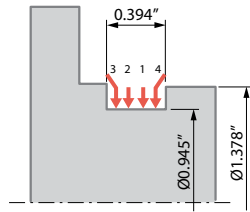

Tool Life

**GM Chipbreaker (PR1225)** **1500 pcs/edge** **6x** ↑ **Tool Life**

**Competitor C (PVD Coated Carbide)** **250 pcs/edge**

KGD + GM chipbreaker (PR1225) improved tool life by 6 times that of Competitor C. No burned chips and good chip control.



**Sleeve 1045 (Cut-off)**

Vc = 340 sfm  
 f = 0.005 ipr  
 Wet  
 GDM3020N-025PM (PR1225)  
 KGDL2525X-3T20S

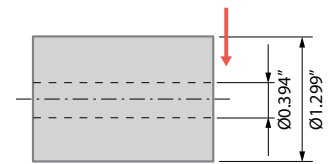

Tool Life

**PM Chipbreaker (PR1225)** **250 pcs/edge, capable of further machining**

**Competitor D (PVD Coated Carbide)** **250 pcs/edge, with chipping**

KGD + PM chipbreaker (PR1225) showed good edge condition after machining same number of workpieces as Competitor D. Available for further machining. (Competitor D showed chipping)

(User evaluation)

**Ball Stud 4137 (Copying)**

Vc = 330 ~ 520 sfm  
 D.O.C. = 0.012"  
 f = 0.006 ~ 0.010 ipr  
 Wet  
 GDM3020N-150R-CM (PR1225)  
 KGDR2020X-3T10S

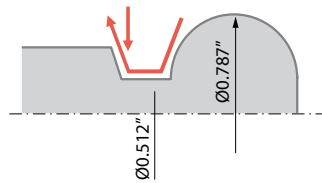

Tool Life

**CM Chipbreaker (PR1225)** **800 pcs/edge** **2x** ↑ **Tool Life**

**Conventional A** **400 pcs/edge**

KGD resolved issues such as chip-biting and tangled chips due to its superior chip evacuation performance.

⇒ Resolved breakage of edge caused by chips.

Doubled tool life by reducing damage on the edge.

(User evaluation)

**Piston 4135H (Face Grooving)**

Vc = 490 sfm  
 D.O.C. = 0.039", 0.071" (Turning)  
 f = 0.002 ipr (Grooving)  
 0.004, 0.006 ipr (Turning)  
 Wet  
 GDFM4020N-040GM (PR1225)  
 KGDFL2525X50 - 4CS

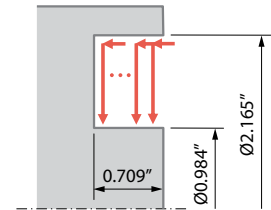

Tool Life

**GM Chipbreaker (PR1225)** **40 pcs/edge, capable of further machining**

**Conventional B** **40 pcs/edge**

KGDF + GM chipbreaker improved chip evacuation compared to Conventional B. (Resolved frequent breakage of toolholder.)

Smaller wear on the edge provided by MEGACOAT makes the tool life longer.

(Lower machining cost with longer tool life)

(User evaluation)



**KYOCERA Precision Tools**

102 Industrial Park Road  
Hendersonville, NC 28792  
Customer Service | 800.823.7284 - Option 1  
Technical Support | 800.823.7284 - Option 2



Official Website | [www.kyoceraprecisiontools.com](http://www.kyoceraprecisiontools.com)  
Distributor Website | [mykpti.kyocera.com](http://mykpti.kyocera.com)  
Email | [cuttingtools@kyocera.com](mailto:cuttingtools@kyocera.com)